

Efficient Solution for **PRIME MOVER**

PRODUCT CATALOGUE

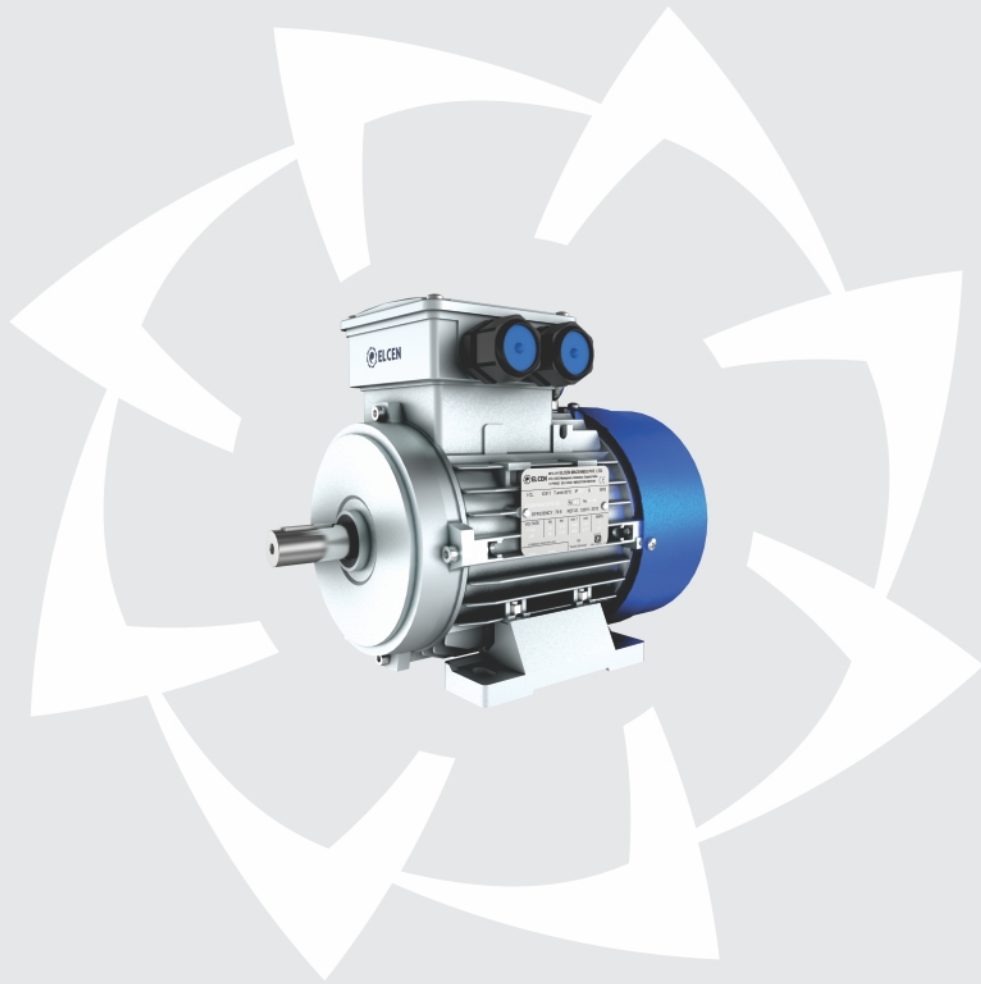

50
YEARS
th
ANNIVERSARY



ELCEN

WHAT IS INSIDE

INFORMATION

Who we are	01
Why Choose Us?	02
Product Range	05
Applicable Standards	06
Mechanical Features	07
Electrical Features	14

ALUMINIUM SERIES

MOAL Series IE2 Hi-Efficient Motors	20
IE 2 Motor (Foot Mounted)	21
IE 2 Motor (Flange Mounted)	22
IE 2 Motor (Face Mounted)	23
Brake Motors	24
Dual Speed Motors	27
Dual Voltage Motors	27
Crane Motors	28
Inverted Rated Motors	29

CAST IRON SERIES

MOCI Series IE2 Hi-Efficient Motors	30
IE 2 Motor (Foot Mounted)	31
IE 2 Motor (Flange Mounted)	32
IE 2 Motor (Face Mounted)	33
Brake Motors	34
Dual Speed Motors	37
Dual Voltage Motors	37
Inverted Rated Motors	38
Torque Motors	39
Crane Motors	40
Custom Built Motors	41

Motor Designation for Inquiry and Order	42
---	----

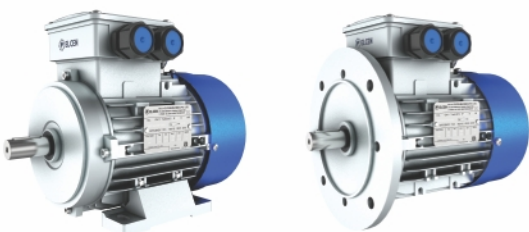



WHO WE ARE...

Welcome to Elcen Machines! We are a leading provider of electric motor solutions for a wide range of industries, core sectors include automotive, pharma, Textile, Food Processing and renewable energy. Our company was founded on the principle of delivering high-quality, reliable, and efficient motors that exceed the expectations of our customers.

We are in business of electric manufacturing electric motors since 1973 under "ELCEN" BRAND. Since inception, the company has excelled in manufacturing and sales of Squirrel Cage Induction Electric Motors, having standard as well as custom built motors. "ELCEN" provides custom built Prime Mover Solutions with timely deliveries, with the best quality. Optimum performance of products keeping in view the customer's specific requirement and product cost.

Our team of experienced engineers and technicians are dedicated to continuously innovating and improving our products, using the latest technologies and materials. Our state-of-the-art manufacturing facility is equipped with advanced machinery and equipment, ensuring that our motors are manufactured to the highest standards.

We are committed to sustainability and operate our business with a focus on reducing our environmental impact. We are proud to be a trusted partner for many of the India's leading companies and organizations. The Titans of Indian Industry & consultant/ Specifiers are now referring ELCEN Motors for most critical and specific application.



Why Choose Us?

ELCEN is a well-known brand synonymous with the latest technology and high quality motors. We have acquired this recognition over the past 3 decades through consistent efforts.

LARGE CAPACITY

Today, our plant at Vadodara, GUJARAT is one of the leading LT motor manufacturing Company in India capable of producing 3000 induction motors /products every month. We are probably the most well-known motor company in India offering customized solutions, with more than 1000 products developed for specific applications.

CUSTOMIZED SOLUTIONS

Thanks to our customer orientation, capabilities in design, development and flexible manufacturing processes, development of non-standard motors for specific applications comes easy to us. We have experience in offering such motors in large quantities and consistent quality levels.

LOW COST OF OWNERSHIP

ELCEN motors is the first choice of several leading Original Equipment Manufacturers and Engineering Projects Contracting companies. We are preferred for competitive prices, quick delivery periods, low running costs and with almost negligible maintenance costs. Time after time ELCEN motors have proved its worth through the recognition of the "lowest cost of ownership"

why ELCEN MACHINES?

On Demand deliveries, Assured consistent quality, Pan-India network, Best-in-class technology, Unflinching after sales service, Ready to respond team, Best suited development, Lower LCC (Life cycle cost), Discerning client profile & Globally acclaimed brand.

EXCELLENT QUALITY

The quality and reliability of our motors is a culmination of multiple efforts which include global technology assimilation, in-house developments, use of latest manufacturing machines, adoption of world-class manufacturing practices and state-of-the-art testing equipment.

ENVIRONMENTALLY - FRIENDLY

ELCEN is an environmentally friendly Co. for two principal reasons. One, we manufacture IE2 energy efficient motors which consume less energy. Two, during the process of manufacturing, we consistently work towards reduction of our carbon footprint by consciously enhancing our reliance on clean energy and adapting energy efficient processes.

WIDE RANGE OF SOLUTIONS

ELCEN offers several types of LT motors up to 225M frame size (up to 60 HP). They include standard induction motors, gear motors, brake motors, energy-efficient motors, encoder motors and different combinations thereof.

ASSURED AFTER SALES SERVICE

ELCEN motors come with a robust post sales service assurance. With authorised service centres across India. ELCEN service is not far away when you need it and is available 24 X 7 round the year. The qualified and experienced team ensures quick response and turn-around resulting in low downtimes. Over the years ELCEN has become one of the most trusted brands for several leading manufacturing companies in India.

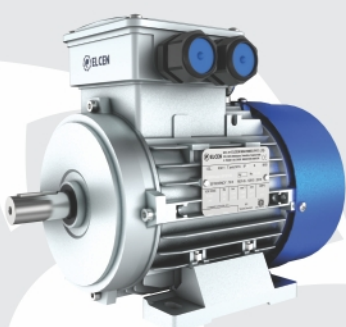

Core Value

INTEGRITY - We do the right thing.

COMMITMENT - We keep our word.

RESPECT - We value people.

EXCELLENCE - We give our best.

Core Purpose

Strive constantly to conserve energy by enhancing efficiency of solution delivered by us. There by contribute to the cause of cleaner, Greener world generation to come.

Mission

Making India proud by becoming largest contributor of producing energy efficient solution with customization

Vision

Provide Solutions for Energy Efficiency which can give product longer life & easy to maintain

PRODUCT RANGE



IE2 Series Hi-Efficient Motors

Frames	63 to 225M
Rating	0.18 kW to 45 kW
Poles	2, 4 & 6
Mountings	B3, B5, B14 & Combi.
Protection	IP55
Enclosure	TEFC

*6 Pole Maximum : 30kW

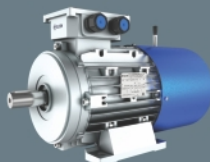

Brake Motors

Frames	63 to 180L
Rating	0.18 kW to 22 kW
Poles	2, 4 & 6
Mountings	B3, B5, B14 & Combi.
Protection	IP54
Enclosure	TEFC
Brake Torque	Up to 250 nm

*6 Pole Maximum : 15kW



Dual Speed Motors

Frames	71 to 132M
Rating	0.18 kW to 5.5 kW
Poles	2/4, 4/6, 4/8 & 6/8
Mountings	B3, B5, B14 & Combi.
Protection	IP55
Enclosure	TEFC
Type	Dual Winding - Dual Speed Single Winding - Dual Speed

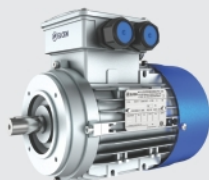

Dual Voltage Motors

Frames	63 to 225M
Rating	0.18 kW to 45 kW
Poles	2, 4 & 6
Mountings	B3, B5, B14 & Combi.
Protection	IP55
Enclosure	TEFC

*6 Pole Maximum : 30kW



Inverted Rated Motors

Frames	63 to 225M
Rating	0.18 kW to 45 kW
Poles	2, 4 & 6
Mountings	B3, B5, B14 & Combi.
Protection	IP55
Enclosure	TEFC & TEFFC
Operating Frequency	10 to 200Hz

*6 Pole Maximum : 30kW



Torque Motors

Frames	63 to 160L
Rating	0.37 kW to 3.7 kW
Poles	4, 6 & 8
Mountings	B3, B5, B14 & Combi.
Protection	IP55
Enclosure	TEFC & TEFFC



Crane Motors

Frames	71 to 200L
Rating	0.18 kW to 37.0 kW
Poles	2, 4 & 6
Mountings	B3, B5, B14 & Combi.
Protection	IP55
Enclosure	TEFC
Starts/hour	60, 100, 150 Nos.



MOCI Series IE3 Hi-Efficient Motors

Frames	37 to 160L
Rating	0.37 kW to 15 kW
Poles	2, 4 & 6
Mountings	B3, B5, B14 & Combi.
Protection	IP55
Enclosure	TEFC & TEFFC

APPLICABLE STANDARDS

“ELCEN” motors pass through stringent quality controls to meet the requirements of National and International Standards

INTERNATIONAL STANDARDS

EQUIVALENT EUROPEAN STANDARDS	TITLE
	Safety of machinery – Electrical equipment of machines
EN 60204-1	Part 1: General Requirements
EN 60034-1	Three phase induction motor – Specifications
EN 60034-1	Type of duty & classes of rating assigned to rotating electrical machines
EN 60034-2	Method of determination of efficiency rotating electrical machines
EN 60034-5	Degree of protection provided by enclosure for rotating electrical machinery
EN 60034-6	Designation of methods of cooling of rotating electrical machinery
	Designation for types of construction & mounting arrangement of
EN 60034-7	Rotating electrical machines
EN 60034-8	Terminal marking & direction of rotation of rotating electrical machinery
EN 60034-9	Permissible limits of noise levels for rotating electrical machines
	Mechanical vibration of rotating electrical machines with shaft height
EN 60034-14	56 mm & higher – Measurements, evaluation & limits of vibration severity
EN 60034-1	Temperature Rise Measurement of rotating Electrical Machines
EN 60072-1	Dimensions of foot mounted induction motors
EN 60072-1	Dimensions of flange mounted induction motors
EN 60034-18	Thermal evaluation and classification of electrical insulation

INDIAN STANDARDS

EQUIVALENT EUROPEAN STANDARDS	TITLE
IS : 900	Code of practice for installation and maintenance of induction motors.
IS : 1231	Dimensions of Foot mounted A.C. induction motors.
IS : 2223	Dimensions of Flange mounted A.C. Induction motors.
IS : 4029	Guide for testing three phase Induction motors.
IS : 4691	Degree of protection provided by Enclosures for Rotating Electrical Machinery.
IS : 6362	Designation of Methods of noise level for Rotating Electrical machines.
IS : 12065	Permissible limits of noise level for Rotating Electrical Machines.
IS : 12075	Mechanical Vibration of Rotating Electrical machines.
IS : 12615	Energy Efficient Induction Motors – Three phase Squirrel Cage.

MECHANICAL FEATURES

STANDARD FEATURES

Body : 63 to 112L Motor frames are available in cast iron as well as aluminum constructions. 112M to 225M Motors Frames are in cast iron constructions only.

End Covers : All end covers and flanges are with integrated bearing housings and of Cast Iron construction.

Terminal Box : Terminal boxes from 63 to 132M frames are of aluminum or Cast Iron construction with Aluminum pressure die cast terminal box with covers. All other frames are with Cast Iron construction with cast iron terminal box covers.

Cable Entry : Except 80 frame are aluminum constructions, all terminal box can be rotated in step of 90 Degree and are provided Metric threads for cable gland. Other threads like PG, B.S. Conduite can be provided.

Shaft : Shafts are manufactured with of EN 8 steel with a tapering in the center to secure pulley or similar types of mountings. Shafts with special diameter and length, with specified shaft material can be manufactured.

Bearings : Single Row Deep Groove Ball Bearings of international Hi-Precision noiseless quality bearing are used on driving end as well as no riving ends.

Lubrication : "ELCEN" motors are fitted High Temperature grease of Lithium Complex soap type, NLGI 2 no, in the bearings, for optimum performance and longer bearings life. (Castrol LCG-2) for high temperature H class insulation motor with molykott-41 high temperature grease in Bearings

Sealing : "ELCEN" Motors are fitted with neon print & silicone oil seals use for protection of the shaft rubber gaskets at terminal box and terminal cover.

Mountings : Standard motors are available with either B3-Foot mounting, B5-Flange mounting. Special mountings can be manufactured suitable to customer's requirements.

Noise Levels : "ELCEN" motors are designed and manufactured to perform silently. The noise levels are within the limits as per EN 60034-9

Balancing and Vibration : All rotating parts, mainly rotor with shaft are dynamically balanced to grade 2.5 for smooth running. However precession grade 1.0 can also be offered if required. Vibration levels of "ELCEN" motor are within the limits as per EN 60034-14.

TERMINAL BOX DATA

Frame Size	Degree of Protection	Thread for Cable Entry		Connection for Temperature Detector		Max. Cable Section mm ²	Terminal thread	Max. External Cable Diam. mm
		PG ¹⁾	Metric ²⁾	PG ¹⁾	Metric ²⁾			
56 - 71	IP 55	1 x Pg 11 x Pg 13.5	1 x M16	-	-	2.5	M4	12
80	IP 55	1 x Pg 13.5 x Pg 16	1 x M20	-	-	2.5	M4	16
90 - 112	IP 55	1 x Pg 13.5 x Pg 16	1 x M25	-	-	4	M5	16
132	IP 55	2 x Pg 21	1 x M32	-	-	4	M5	20
160	IP 55	2 x Pg 29	1 x M40	Pg 11	M 20	16	M6	28
180	IP 55	2 x Pg 29	1 x M40	Pg 13.5	M 20	35	M8	28
200	IP 55	2 x Pg 36	1 x M50	Pg 16	M 25	35	M8	34
225	IP 55	2 x Pg 36	1 x M50	Pg 16	M 25	50	M10	34
250 - 280	IP 55	2 x Pg 42	1 x M63	Pg 16	M 25	50	M10	40
315	IP 55	2 x Pg 48 ³⁾	1 x M63 ³⁾	2 x Pg 16	M 25	185	M12	48

1) Pg threat to DIN 40 430 2) Pitch 1.5 3) Terminal box with unscrewable cable entry plate

EFFECT OF VARIATION VOLTAGE AND FREQUENCY ON MOTOR PERFORMANCE

Characteristics	Voltage		Frequency	
	110%	90%	105%	95%
Torque Starting & Maximum	Increase 21%	Decrease 19%	Decrease 10%	Increase 11%
Speed				
Synchronous	No Change	No Change	Increase 5%	Decrease 5%
Full Load	Increase 1%	Decrease 1.5%	Increase 5%	Decrease 5%
Current				
No Load	Increase 10-15%	Decrease 10-12%	Decrease 5-6%	Increase 5-6%
Starting	Increase 10-12%	Decrease 10-12%	Decrease 5-6%	Increase 5-6%
Full Load	Decrease 7%	Increase 11%	Slight Decrease	Slight Decrease
Temp Rise	Decrease 3-4°C	Increase 6-7°C	Slight Decrease	Slight Decrease
Over Load Capacity	Increase 21%	Decrease 19%	Slight Decrease	Slight Decrease
MAG Noise	Slight Increase	Slight Decrease	Slight Decrease	Slight Increase
Efficiency				
Full Load	Increase 0.5-1%	Decrease 2%	Slight Increase	Slight Decrease
Power Factor				
Full Load	Decrease 3%	Increase 1%	Slight Increase	Slight Decrease

BEARING ARRANGEMENT

Frame Size	B3		B5		B14		B35		B34		Brake
	DE	NDE	DE	NDE	DE	NDE	DE	NDE	DE	NDE	NDE
63	6201ZZ	6201ZZ	6201ZZ	6201ZZ	6201ZZ	6201ZZ	6201ZZ	6201ZZ	6201ZZ	6201ZZ	6201ZZ
71	6202ZZ	6202ZZ	6202ZZ	6202ZZ	6202ZZ	6202ZZ	6202ZZ	6202ZZ	6202ZZ	6202ZZ	6203ZZ
80	6204ZZ	6203ZZ	6204ZZ	6203ZZ	6204ZZ	6203ZZ	6204ZZ	6203ZZ	6204ZZ	6203ZZ	6204ZZ
90S	6205ZZ	6205ZZ	6205ZZ	6205ZZ	6205ZZ	6205ZZ	6205ZZ	6205ZZ	6205ZZ	6205ZZ	6205ZZ
90L	6205ZZ	6205ZZ	6205ZZ	6205ZZ	6205ZZ	6205ZZ	6205ZZ	6205ZZ	6205ZZ	6205ZZ	6205ZZ
100L	6206ZZ	6206ZZ	6206ZZ	6206ZZ	6206ZZ	6206ZZ	6206ZZ	6206ZZ	6206ZZ	6206ZZ	6206ZZ
112M	6306ZZ	6306ZZ	6306ZZ	6306ZZ	6306ZZ	6306ZZ	6306ZZ	6306ZZ	6306ZZ	6306ZZ	6306ZZ
132S	6208ZZ	6208ZZ	6208ZZ	6208ZZ	6208ZZ	6208ZZ	6208ZZ	6208ZZ	6208ZZ	6208ZZ	6208ZZ
132M	6208ZZ	6208ZZ	6208ZZ	6208ZZ	6208ZZ	6208ZZ	6208ZZ	6208ZZ	6208ZZ	6208ZZ	6208ZZ
160M	6309	6209	6309	6209	-	-	6309	6209	6309	6209	6309
160L	6309	6209	6309	6209	-	-	6309	6209	6309	6209	6309
180L	6310	6310	6311	6310	-	-	6311	6310	6311	6310	6310
180M	6310	6310	6311	6310	-	-	6311	6310	6311	6310	6310
200L	6313	6313	6314	6313	-	-	6314	6313	6314	6313	6313
225M	6313	6313	6314	6313	-	-	6314	6313	6314	6313	6313

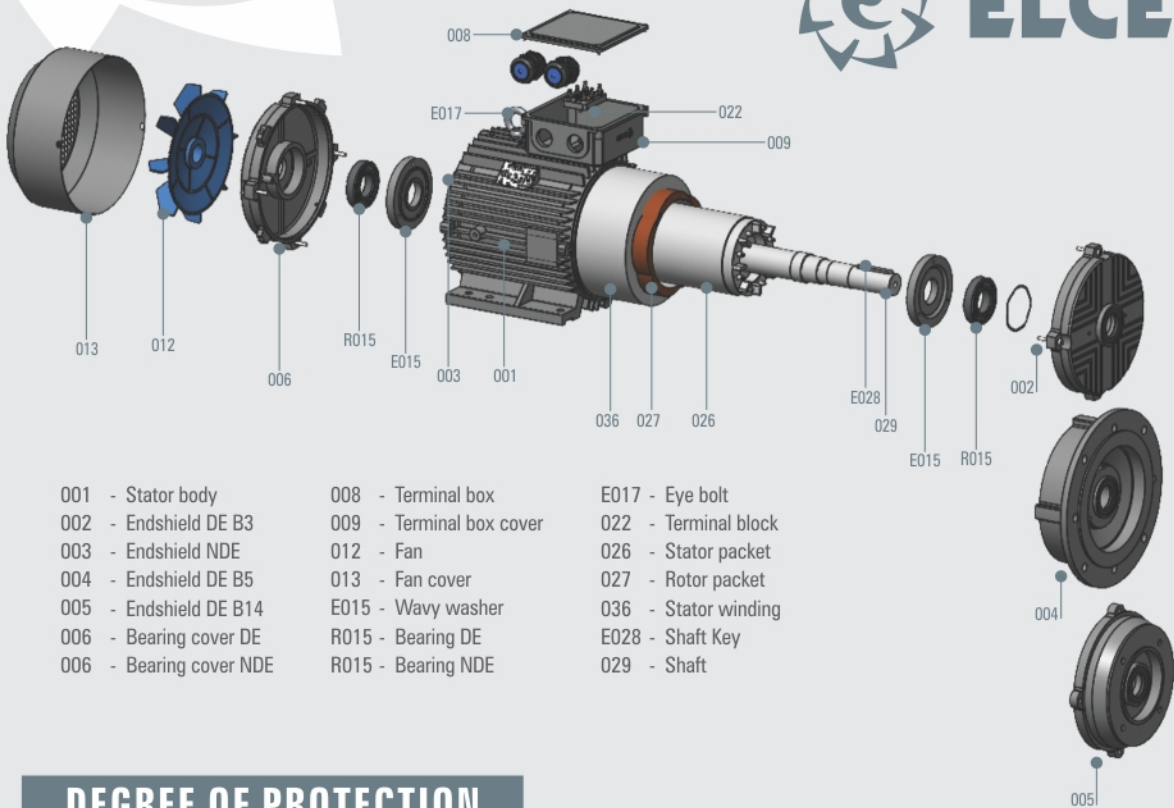

- | | | |
|-------------------------|--------------------------|----------------------|
| 001 - Stator body | 008 - Terminal box | E017 - Eye bolt |
| 002 - Endshield DE B3 | 009 - Terminal box cover | 022 - Terminal block |
| 003 - Endshield NDE | 012 - Fan | 026 - Stator packet |
| 004 - Endshield DE B5 | 013 - Fan cover | 027 - Rotor packet |
| 005 - Endshield DE B14 | E015 - Wavy washer | 036 - Stator winding |
| 006 - Bearing cover DE | R015 - Bearing DE | E028 - Shaft Key |
| 006 - Bearing cover NDE | R015 - Bearing NDE | 029 - Shaft |

DEGREE OF PROTECTION

The degree of protection as classified in IS 4691 is given below. It is denoted by two digit. The first digit denotes protection against solid bodies or particles and the second digit denotes protection against liquid. All our standard TEFC motor have degree of protection IP 55, unless otherwise specified.

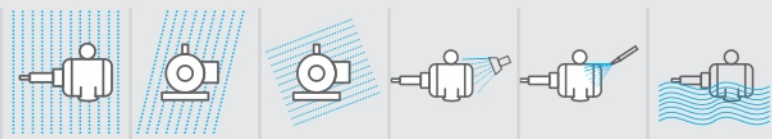
Second Characteristic								
		0	1	2	3	4	5	6
First Characteristic Numeral	No Protection							
	0							
1	Special Protection against bodies 50 mm dia.							
2	DP protection against bodies 12 mm dia.		IP 21	IP 22	IP 23			
4	TEFC Protection against bodies 1mm dia.					IP 44		
5	TEFC Protection against powder					IP 54	IP 55	IP 56
	No Ingress of dust						IP 65	

PERMISSIBLE RADIAL LOAD

The Output Shaft of the motors can be subject to Radial Loads which depends on the type and size of pulley/pinion and also type of driven machine.

The extent of which can be calculated with the following formula.

$$R = \frac{p \times 973 \times kW}{RPM \times D/2} + Wt$$

Where R = Radial Load
 p = 1, for chain
 p = 1.25 for gear
 p = 1.5 - 2.5 for v-belt
 kW = output of the motor in kW
 RPM = RPM of the motor
 D = diameter of the pulley / sprocket / gear in mm
 W = weight of the pulley / sprocket / gear.

DEPENDING ON THE APPLICATION THERE MUST BE TWO CASES FOR RADIAL LOADS.

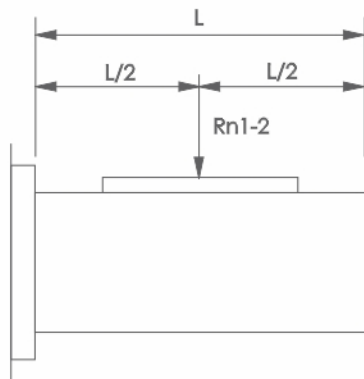

Load applied on shaft at Mid-Point as shown above

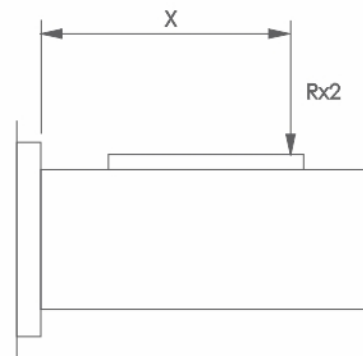

Load applied at X distance from shaft shoulder as shown above

For radial loads other than those recommended in the Table below customers are advised to consult Elcen machines Pvt. Ltd. For maximum allowable loads.

FRAME SIZE	SYNCHRONOUS RPM & RADIAL LOAD IN KG.				PERMISSIBLE AXIAL LOAD IN kg	RECOMMENDED PULLEY SIZE DIA X WIDTH (D X W) IN mm
	3000 (3600)	1500 (1800)	1000 (1200)	750 (900)		
63	30	30	30	30	10	10
71	25	35	35	35	12	12
80	50	60	60	60	20	20
90	55	55	65	75	25	25
100	70	80	80	100	35	35
112	95	110	110	110	40	40
132	150	175	200	210	50	50
160	260	300	325	350	70	70
180	325	350	400	400	80	80
200	425	500	575	575	100	100
225	450	600	650	650	100	100

INSTALLATION POSITIONS

Different applications demand different installation positions. It is always better to keep in mind the installation position and the type of load while selecting the motor. However, the construction and general arrangement of motors remains the same for almost all installation positions.

MOTOR INSTALLATION POSITIONS

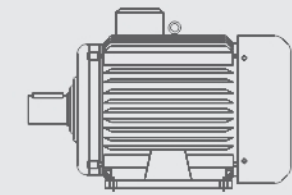

B3

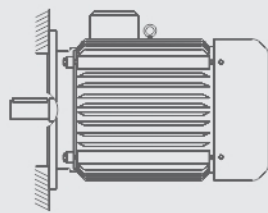

B5

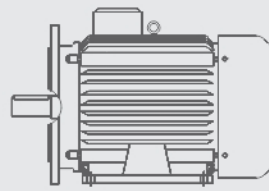

B35

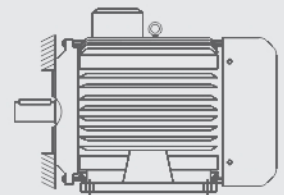

B34

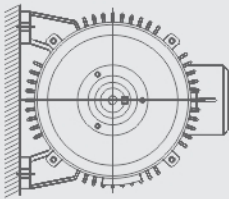

B6

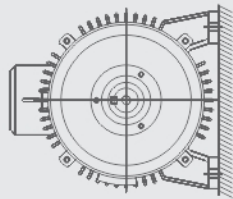

B7

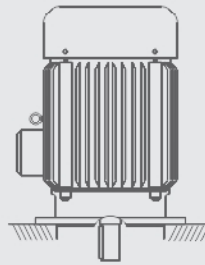

V1

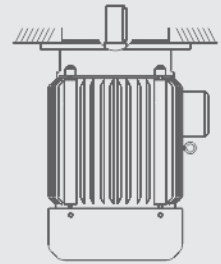

V3

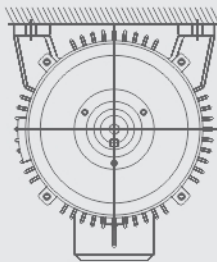

B8

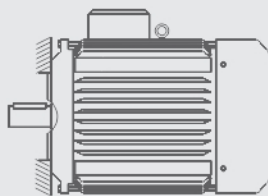

B14

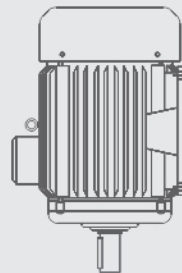

V5

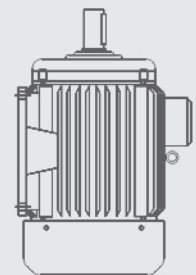

V6

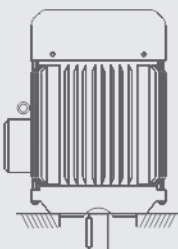

V18

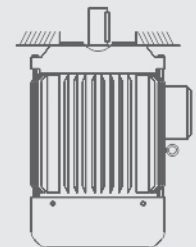

V19

SELECTION OF MOTORS

The kilowatt requirement of the motor can be obtained by the following formula

1. For horizontal motion

$$PL = \frac{F \times V}{102 \times L}$$

Where:

PL = Kilowatt required

F = Max total load in kg

V = Hoisting speed in Mtrs / Second

L = O/A eff. Of the driving unit:

2. For rotary motion

$$PL = \frac{M \times N}{974 \times \text{Eff.}}$$

Where:

M = Torque for movement in kgm

N = Motor speed in RPM

Ensure the rated output of motor is greater than the power PL



TOLERANCE ON DIMENSIONS





Dimension	Tolerances
Frame Size H ≤ 250	0, - 0.5 mm
≥ 280	0, - 0.5 mm
Diameter D of Shaft extension:	
• 11 to 28 mm	j6
• 32 to 48 mm	K6
• 55mm and over	m6
Diameter N of Shaft spigot:	
Up to F 500 B	j6
Above F 500 B	js6
Key Width	h9
Width of driveshaft keyway (keying)	N9
Key depth:	
• Square section	h9
• Rectangular section	h11

Dimension	Tolerances
Eccentricity of shaft in flanged motors (Standard class):	
D ≤ 10 mm	0.030 mm
10 mm < D ≤ 18 mm	0.035 mm
18 mm < D ≤ 30 mm	0.040 mm
30 mm < D ≤ 50 mm	0.050 mm
50 mm < D ≤ 80 mm	0.060 mm
80 mm < D ≤ 120 mm	0.070 mm
Concentricity of spigot diameter and perpendicularity of mating surface of flange to shaft (standard class)	
Flange:	
F65 to F115	0.080 mm
F130 to F265	0.100 mm
F300 to F500	0.125 mm
F600 to F740	0.160 mm
F940 to F1080	0.200 mm

TOLERANCE ON PERFORMANCE PARAMETERS

Performance Parameter	Tolerances
Efficiency (η):	
a) By summation of losses:	
I) Motors $P \geq 50$ kW	- 15% (1- η)
II) Motors $P > 50$ kW	- 10% (1- η)
b) by input P - output test	- 15% (1- η)
Total losses applicable to motors $P > 50$ kW	+ 10% of total losses
Power factor (Cos \emptyset)	- 1/6 of (1-Cos \emptyset); min 0.02, max 0.07
Slip at full load and at working temperature :	
a) For machines having output 1 kW (or kVA) or more:	\pm 20% of the guaranteed slip
b) For machines having output less than 1 kW (or kVA):	\pm 30% of the guaranteed slip
Breakaway starting current (Ist) with the Specified starting method/apparatus	+20% of the guaranteed starting current (no negative tolerance)
Breakaway Torque (Tst)	-15% to +25% of the guaranteed torque (+ 25% may be exceeded by agreement between manufacturer & Purchaser)
Pullout Torque (Tpo)	-10% of the guaranteed torque except that after allowing for this tolerance, the torque shall not be less than 1.6 or 1.5 times the rated torque
Moment of inertia or stored energy constant for motors above 315 frame	+ 10% of the guaranteed value

RATING PLATE

 MFG. BY ELCEN MACHINES PVT. LTD. 270, GIDC Makarpura, Vadodara, Gujarat, India. 3 PHASE SQ CAGE INDUCTION MOTOR 					
I.CL. IC411 T.amb 50°C IP 55 S1 IM B3					
ES80P4A415FS1B3		Kg: 39.7	No. 264966		
EFFICIENCY : 79.6		REF-IS : 12615 : 2018			
VOLTAGE	Hz	kw	min-1	cos	AMPS
Y 415	50	0.75	1390	0.77	1.7
240	50	0.75	1390	0.77	2.9
(COMBINED VARIATION: \pm 5%)					
6204ZZ		6204ZZ	 *Sold & Serviced MADE IN INDIA		 CML-7200112889

ELECTRICAL FEATURES

The various operating cycle of driven machines can be classified into nine basic duties, ranging from S1 to S9 separately indicated in the following pages. Suitable motors can be offered to match the duty cycle of the driven machines.

CLASSES OF DUTY

The following are the duty types:

Duty	Type	Description	Application
S1	Continuous duty	Operation at constant load of sufficient duration for thermal equilibrium to be reached. These are our Standard Motors.	Pumps, Blowers, Fan Compressors
S2	Short time duty	<p>Operation at constant load during a given time, less than that required to reach thermal equilibrium, followed by a rest of sufficient duration to re-establish equality of temperature with the cooling medium.</p> <p>The recommended values for the short-time duty are 10, 30, 60 and 90 minutes.</p> <p>These motors are generally suitable for valve Actuators, Mixers etc.</p>	Operation of gates of dams, siren, Capstan
S3	Intermittent periodic duty	<p>A sequence of identical duty cycles, each consisting of a period of operation at constant load and a rest periods being too short to attain thermal equilibrium during one duty cycle. In the duty type, the starting current does not significantly affect the temperature-rise. Unless otherwise specified, the duration of the duty cycle is 10 minutes.</p> <p>The recommended values for the load factor are 15, 25, 40 and 60 percent.</p> <p>These motors also come in Crane Duty Applications and the Duty Cycle is designated as S3 – 40%, S3 – 60%. The No of Starts is also less; either 45 or 60 Starts / hour</p>	Valve actuators, Wire drawing machines
S4	Intermittent periodic duty with starting	<p>A sequence of identical duty cycles each consisting of a period of starting, a period of operation at constant load and a rest period, the operating and rest and de-energized being too short to attain thermal equilibrium during one duty cycle.</p> <p>In this duty the stopping of the motor is obtained either by natural deceleration after disconnection of the electricity supply or by means of braking such as mechanical brake which does not cause additional heating of the windings.</p> <p>These are generally suitable for Crane Duty/Lift Duty Applications where Moment of Inertia of the load is maximum equal to Moment of Inertia of the Motor.</p> <p>Either one has to offer these motors in higher frame size or with extra Active material and with LM6 Rotors or a MS Rotor or a MS Rotor, to reduce the Starting Losses.</p> <p>The Duty Designation is mentioned as S4 – 60% CDF, 150 Starts / hr etc.</p>	Hoist, Cranes, Lifts
S5	Intermittent periodic duty with starting and braking	<p>A sequence identical duty cycles each consisting of a period of starting, a period of operation at constant load, a period of braking and a rest period. The operating and de-energized periods being too short to obtain thermal equilibrium during one duty cycle.</p> <p>In this duty braking is rapid and is carried out electrically.</p> <p>These are motors where generally Braking is done through Electromagnetic DC Brakes as normal Brake Motors or by Injection of DC Voltage in the Rotor. Since the Braking is done electrically, the Braking Losses are also added to the Starting Losses, thus making this Duty most stringent and heavy.</p> <p>The Duty Designation is mentioned as S5 – 60% CDF, 300 Starts / hr etc.</p> <p>Either one has to offer these motors in higher frame size or with extra Active material and with LM6 Rotor or a MS Rotor, to reduce the Starting Losses.</p>	Hoist, Cranes, Rolling Mills
S6	Continuous duty with intermittent periodic loading	<p>A sequence of identical duty cycles each consisting of a period of operation at constant load and a period of operation at no-load, machines with excited windings having normal no-load rated voltage excitation. The operation and no-load periods are too short to attain thermal equilibrium during one duty cycle.</p> <p>Unless otherwise specified the duration of the duty cycle is 10 minutes.</p>	Conveyors, Machines Tools

Duty	Type	Description	Application
S7	Continuous duty with starting and braking	<p>The recommended values of cyclic duration factor are 15, 25, 40 and 60 percent. This Duty is different from S2 duty, as in S2 Duty there is a period of rest after the On-Load operation.</p> <p>Normal S1 duty motors are suitable to operate on S6 Duty provided the Load Inertia is maximum equal to Motor Inertia is maximum equal to Motor Inertia</p> <p>A sequence of identical duty cycles each consisting of a period of starting, a period of operation at constant load and a period of electrical braking. There is no rest and de-energized period.</p> <p>This is also a very stringent duty Application similar to S5 Duty Motors, except in this case there is no rest period. These motors may be used for Balancing Machines, Tapping Applications. Either one has to offer these motors in higher frame size or with extra Active material and with LM6 Rotor or a MS Rotor, to reduce the Starting Losses.</p>	Machine Tools
	Continuous duty with periodic speed changes	<p>A sequence of identical duty cycles each consisting of a period of operation at constant load corresponding to a determined speed of rotation, followed immediately by a period of operation at another load corresponding to a different speed of rotation (carried out, for example, by means of change of the number of poles in the case of induction motors), the operating periods being too short to attain equilibrium during one duty cycle. There is no rest and de-energized period.</p> <p>These motors are always Multi-speed Motors e.g. 4P/2P, 8P/4P, 6P/4P etc.</p> <p>Here the Speed change is done by Pole Changing method. This is achieved by connecting the Motor terminals in two different ways to achieve 2 different speeds.</p>	Special applications where the motor is required to run at different speeds and different loads
S8	Duty with non-periodic load and speed variations	<p>A duty in which generally load and speed are varying non-periodically within the permissible operating range. This duty includes frequently applied overloads that may greatly exceed the full loads. For this loads. For this duty type, suitable load values should be taken as the basis of the overload concept.</p>	Special applications where the motor is required to run at different speeds and different loads

DESIGNATION

A duty type is designated by mean of the abbreviation given below. For the duty type S2 the abbreviation is followed an indication if the duration of the duty. For duty type S3 and S6 the abbreviations are followed by an indication of the cyclic duration factor.

Examples: S2 60 minutes S3 25 percent S6 40 percent

For the duty types S4 and S5 the abbreviation are followed by the indication of the cyclic duration factor, the number of duty cycles per hour (c/h) and the factor of inertia (FI)

Example: S4 25 percent 120 Starts / hr Load factor =2 (Load Factor = Load Inertia / Motor Inertia)

For the duty type S7 the abbreviation is followed by the number of cycles per hour and the factor of inertia.

Example: S7 500 Starts / hr Load Factor = 2

For the duty type S8 and S9 the abbreviation is followed by the indication of the number of duty cycles per hour and the factor inertia together with the load. In addition, the cyclic duration factor should be indicated for each speed.

Examples: S8 or S9 30 Starts / hour Load Factor = 3

S2/S3 RATED MOTOR OUTPUTS

Standard motors can be used for S2 and S3 duties with increased outputs. However, the starting torque and pullout torque as percentage of full load torque would be reduced. The ratings indicated in the table are with minimum 200% pull out torque.

TEMPERATURE RISE AND INSULATION CLASS

Normally motors are insulated to Class "F" with a temperature rise restricted to Class "B". Class "H" insulation can be produced if required. All the motor winding with VPI treatments



Class of Insulation	Max. Permissible Temp. Limit °C	Max. Permissible Temperature rise for winding at Ambient Temperature in °C		
		40°C	45°C	50°C
B	130	80	75	70
F	155	105	100	95
H	180	125	120	115

DERATING FACTOR

Deratings and performance values are specified at 40°C ambient temperature and below 1000 meter altitude. However the same motor can be used with higher ambient temperature and altitude but has to be derated as specified in adjoining tables.



Class of Temperature in °C	% Output of Motor
30°C - 45°C	103 %
50°C	100 %
55°C	96 %
60°C	92 %



Altitude above Sea level in meter	% Output of Motor
2000	95
3000	85
4000	77

MOTOR PROTECTION

Normally motors are protected against over current by overload relays, fuses or MCBs. For thermal protection, motors can be supplied with thermister or thermal switch. For condensing environments, motors with space heaters can be supplied as well. The table below is a general guide line for selection of fuse ratings.



DOL Starting

kw/hp	0.37/0.5	0.55/0.75	0.75/1.0	1.1/1.5	1.5/2.0	2.2/3.0	3.7/5.0	5.5/7.5	7.5/10	9.3/12.5	11/15	15/20	18.5/25	22/30	30/40	37/50	45/60
Avg. Current	1.1	1.4	1.9	2.6	3.7	4.8	7.8	11.2	15	18	21	27	33	39	53	65	78
Fuse Rating	4	6	6	6	10	16	16	25	25	35	35	50	63	63	100	100	160
Relay Range	1-2	1-2	1-2	2-4	2-4	3-6	6-12	6-12	10-16	18-24	18-24	16-32	24-45	24-45	32-63	50-90	50-90

STAR - DELTA Starting

kw/hp		2.2/3.0	3.7/5.0	5.5/7.5	7.5/10	9.3/12.5	11/15	15/20	18.5/25	22/30	30/40	37/50	45/60
Average Current	Line	4.8	7.8	11.2	15	18	21	27	33	39	53	65	78
	Phase	2.8	4.5	6.5	9	11	12.7	16.8	20.2	23.2	30.6	37.5	46.4
Fuse Rating		16	16	25	25	35	35	50	63	63	100	100	160
Relay Range		1.5-3	3-6	4-8	6-12	6-12	10-16	18-24	18-24	18-24	16-32	24-45	32-63

WIRING GUIDELINES

Motors with six terminals have to be connected in accordance with supply conditions. Verify the connection instruction before putting the motor in operation. With different connections of the motor, it is possible to use the same motor at different voltage supplies (Dual voltage motor)

Star Connection – On Six termination plate, connect U2, V2 and W2 with link supplied along with the motor and connect three phase supply wires to U1, V1 and W1 to connect the motor in star connection.

Delta Connection – On a Six Termination plate, connect V1-U2, U1-W2 and W1-V2 with the link supplied along with the motor and connect three phase supply wires to U1, V1 and W1 to connect end of one phase to beginning of next phase.

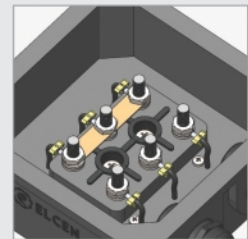

While changing the connections, ensure that the rated Voltage is maintained on the supply to brake, rectifier or any other type of equipment that is directly connected to the motor termination.

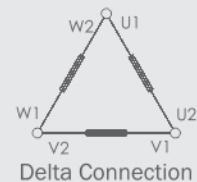
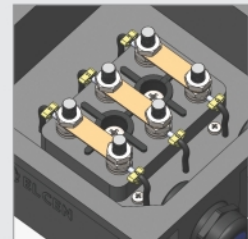

	VOLTS				
Delta	110	125	220	240	415
Star	190	220	380	415	690

MECHANICAL VIBRATION

Limits of vibration of rotating electrical machines is defined in IS: 12075. This is applicable for machines with shaft height 56mm and higher having a nominal speed from 500 rpm up to and including 3000 rpm.

The measurements are carried out under no load, uncoupled condition in a state of free suspension (suspension by resilient means such as rope, V-belt, spring or freely placed on test bed) or Rigid mounting (for motors with shaft height greater than 400mm)

NOISE LEVEL

Permissible limits of noise levels for rotating electrical machines are defined in IS: 12065. Machines are to run at no load, uncoupled condition. Measurements are carried out at a distance of 1m in the horizontal and vertical planes of the machine.

TESTING

The standard test programmes are divided into four parts: routine tests type tests, optional tests and special tests. The routine test program is done to every machine and it is included in price of the machine. Type test is performed in addition to routine tests normally to one of the machines of a series of similar machine or by a request of the customer. Optional tests and special test are additional type tests subject to mutual agreement between purchaser and the manufacturer.

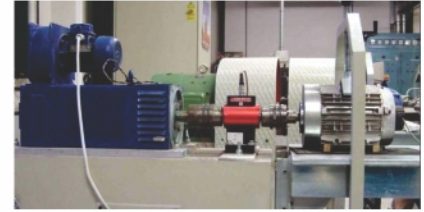

CONTENTS OF TEST PROGRAMMES:

ROUTINE TESTS

1. Insulation resistance test
2. Measurement of resistance of the stator
3. High voltage test
4. Reduced voltage running test
5. No load test
6. Locked rotor test

OPTIONAL TESTS

1. Vibrational severity test
2. Sound level measurement
3. Temp. rise test at limiting values of voltage & frequency variation
4. Over speed test
5. Test on insulation system

TYPE TESTS

1. Dimensions
2. Measurement of resistance of stator
3. Locked rotor test
4. Temperature rise test
5. Full load test
6. No load test at rated voltage
7. Reduced voltage running test
8. Momentary overload test
9. Insulation resistance test
10. High voltage test

SPECIAL CUSTOMIZED DESIGNS

Frame	Pole / Synchronous RPM At 50 (60) Hz											
	56	63	71	80	90	100	112	132	160	180	200	225
Electrical												
Non std voltage &/or freq.	■	■	■	■	■	■	■	■	■	■	■	■
Gelcoat on winding overhang	■	■	■	■	■	■	■	■	■	■	■	■
Insulation class H	■	■	■	■	■	■	■	■	■	■	■	■
Two speed motors	N	■	■	■	■	■	■	■	■	■	■	■
High torque motors	■	■	■	■	■	■	■	■	■	■	■	■
Special performance requirements	■	■	■	■	■	■	■	■	■	■	■	■
Mechanical												
Second std shaft end	■	■	■	■	■	■	■	■	■	■	■	■
Non std shaft end	■	■	■	■	■	■	■	■	■	■	■	■
Shaft length = 2E	■	■	■	■	■	■	■	■	■	■	■	■
B3, B6, B7, B8, V5, V6 mtg.	□	□	□	□	□	□	□	□	□	□	□	□
B5, V1, V3, mtg.	□	□	□	□	□	□	□	□	■	■	■	■
B14, V18, V19 mtg.	□	□	□	□	□	□	□	□	■	-	-	-
B35, V15 mtg.	■	■	■	■	■	■	■	■	■	■	■	■
B34 mtg.	■	■	■	■	■	■	■	■	-	-	-	-
Non std flange	■	■	■	■	■	■	■	■	■	■	■	■
Spl. Vibration level	■	■	■	■	■	■	■	■	■	■	■	■
Epoxy paint	■	■	■	■	■	■	■	■	■	■	■	■
Thermistors, RTD, BTS	N	N	N	N	N	■	■	■	■	■	■	■
Space heaters	N	N	N	N	N	N	N	N	N	N	□	□
Regreasing arrangement	■	■	■	■	■	■	■	■	■	■	■	■
Colour other than RAL 6011	■	■	■	■	■	■	■	■	■	■	■	■
Special shaft material	■	■	■	■	■	■	■	■	■	■	■	■
Special bearings	■	■	■	■	■	■	■	■	■	■	■	■
Force cooling arrangement	N	N	N	N	N	■	■	■	■	■	■	■

A Available upon request

N Cannot be supplied

□ No extra cost

■ Extra cost

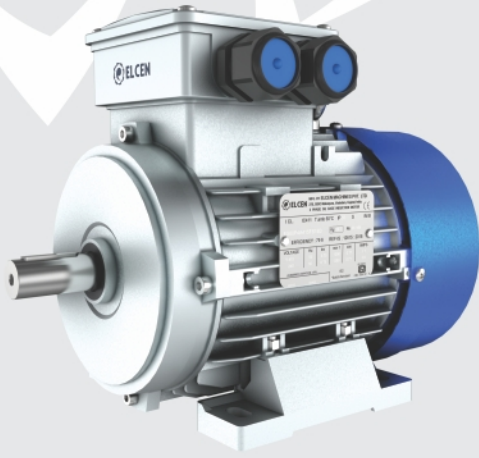

TO MEET THE INTERNATIONAL STANDARDS AND TRENDS,
 “ELCEN” THREE PHASE MOTORS ARE AVAILABLE IN STANDARD FRAMES AS
 INDICATED IN TABLE BELOW. CERTAIN MOTORS ARE ALSO AVAILABLE IN
 DIFFERENT FRAMES AS INDICATED IN (BRACKET)

FRAME V/S OUTPUT SUMMARY

Pole / Synchronous RPM At 50 (60) Hz

KW	HP	2 / 3000 (3600)	4 / 1500 (1800)	6 / 1000 (1200)
0.18	0.25	63	63	71
0.25	0.33	63(71)	71	71
0.37	0.50	71	71	80
0.55	0.75	71(80)	80(71)	80
0.75	1.00	80	80	90S
1.10	1.50	80	90S(80)	90L
1.50	2.00	90S	90L	100L
2.20	3.00	90L	100L	112M
3.70	5.00	100L	112M	132S
5.50	7.50	132S	132S	132M
7.50	10.0	132S	132M	160M
9.30	12.5	132M	160M{132M}	160M
11.0	15.0	160M	160M	160L
15.0	20.0	160M	160L	180L
18.5	25.0	160L	180M	200L
22.0	30.0	180M	180L	200L
30.0	40.0	200L	200L	225L
37.0	50.0	200L	225S	
45.0	60.0	225M	225M	

ALUMINIUM SERIES

MOAL SERIES IE2 HI-EFFICIENT MOTORS

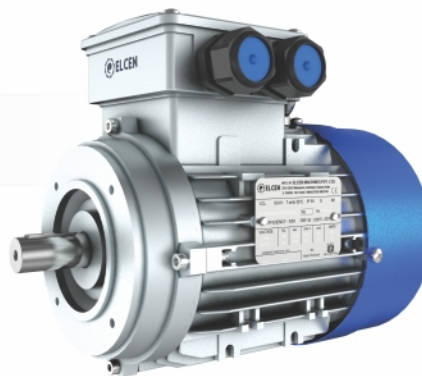

In today's power scenario, we are facing a major power crunch. Day by day, the gap between demand & supply of electric energy is widening at the rate of 3%. Bridging this gap from supply side is very difficult & expensive proposition. The only viable way in handling these crises, in addition to capacity addition, is the efficient use of available energy, which is possible by use of energy efficient devices.

Electric motors are industry's basic need. Electric motors consume around 70% of the total electricity used in the industrial sector. As motors are the largest users of electrical energy, even small efficiency improvements can produce large savings across the country. Energy conservation measure taken by individual consumers in this direction can improve the national economy & benefit the environment on global scale. An energy efficient motor produces the same shaft output power but draws less input power than a standard motor. Hence energy efficient motor consumes less electricity than comparable standard motor.

FEATURES

- Standards : IS: 12615, IS: 1231, IS: 2223 & IEC-60034-1
- Mounting : Foot (B3), Flange (B5), Face (B14) & combi.
- Voltage : 415V \pm 10% or as required
- Frequency : 50Hz \pm 5% or as required
- Ambient : 50°C.
- Altitude : Upto 1000m above m.s.l.
- Enclosure : Totally enclosed fan cooled (TEFC)
- Protection : IP55
- Ins. Class : Class F Ins. With temp. rise limited to class B.

ADVANTAGES

- ▣ Saves energy & money
- ▣ Near uniform efficiency from 50% to 100% of full load ensuring energy savings even at part load conditions
- ▣ Short payback period
- ▣ Substantial savings after payback period

RANGE

"ELCEN" Energy efficient motor are designed as per the values specified in IS: 12615. They have near uniform efficiencies between 50 & 100% of load as shown in the figure. The motors are available from 2.2kW to 200.0kW in 2 & 4 pole variety as given in the performance tables. Performance figures of 6 & 8 pole motors are available upon request



EFFICIENCY LEVEL

"ELCEN" standard motors are with IE 2.

Pole	Kw	0.37	0.55	0.75	1.1	1.5	2.2	3.7	5.5	7.5	11	15	18.5	22	30	37	45
2	Efficiency in %	72.2	74.8	77.4	79.6	81.3	83.2	85.5	87	88.1	89.4	90.3	90.9	91.3	92	92.5	92.9
		70.1	75.1	79.6	81.4	82.8	84.3	86.3	87.7	88.7	89.8	90.6	91.2	91.6	92.3	92.7	93.1

ALUMINIUM SERIES



IE2 - MOTOR (FOOT MOUNTED)

Mechanical Dimension (B3 Construction)

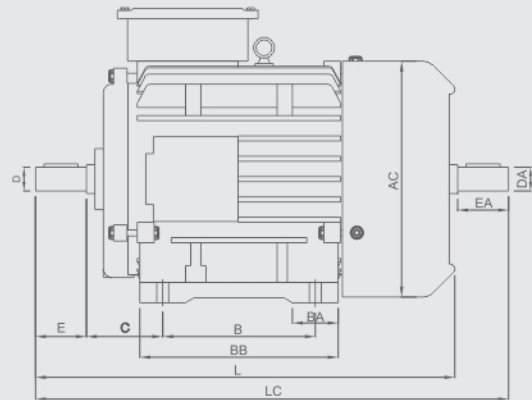
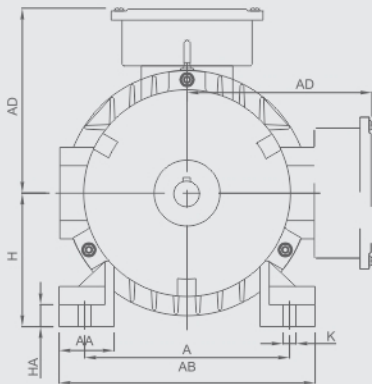

Frame Size	A	B	C	H	K	L	LC	AA	AB	BB	BA	AC	HA	U	AD	D	DA	E	EA	F	FA	GA	GC	G	GB	TOL ON D, DA	TOL ON F, FA	TOL ON H
63	100	80	40	63	7	212	245	31	125	105	25	122	10	M4	95	11	23	4	12.5	8.5					+0.008 -0.003 (j6)	+0 -0.030 (h9)		
71	112	90	45	71	7	240	275	35	140	108	35	134	10	M5	111	14	30	5	16	11								
80	125	100	50	80	10	278	323	40	160	125	40	156	13	M6	128	18	40	6	21.5	15.5								
90S	140	100	56	90	10	312	369	37	175	132	45	176	14	M8	135	24	50	8	27	20								
90L	140	125	56	90	10	329	386	37	175	157	45	176	14	M8	135	24	50	8	27	20					+0.009 -0.004 (j6)	+0 -0.036 (h9)	±0.5	
100L	160	140	63	100	12	369	434	42	200	170	50	192	14	M10	165	28	60	8	31	24								
112M	190	140	70	112	12	391	456	50	225	175	57	217	14	M12	178	28	60	8	31	24								

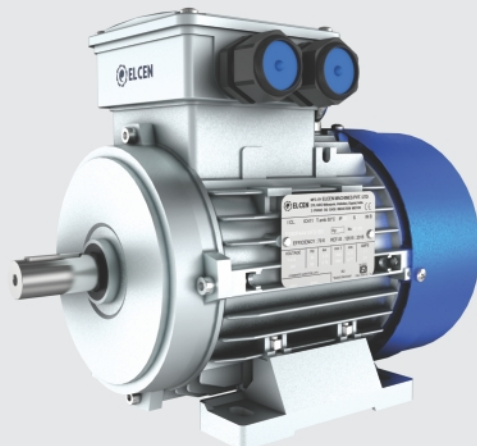
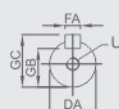
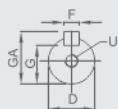

ALUMINIUM SERIES

IE2 - MOTOR (FLANGE MOUNTED)

Mechanical Dimension (B5 Construction)

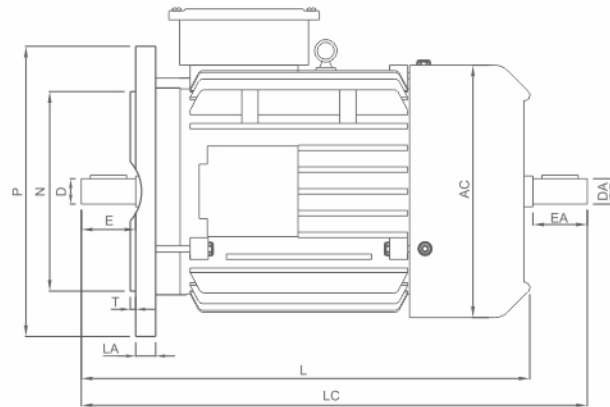
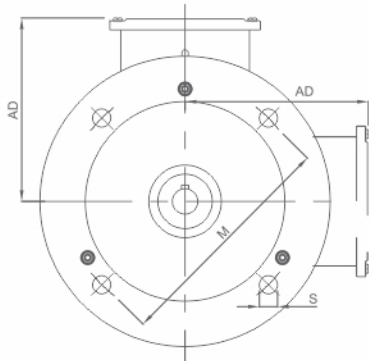

Frame Size	L	LC	AC	AD	U	D DA	E EA	F FA	GA GC	G GB	P MAX	M	N	S	T MAX	LA	TOL ON D,DA	TOL ON F,FA	TOL ON H
63	212	242	122	95	M4	11	23	4	12.5	8.5	90	75	60	M5	2.5	9	+.0087 -.003 (j6)	+.0 -.030 (h9)	±0.3
71	238	275	134	111	M5	14	30	5	16	11	105	85	70	M6	2.5	9			
80	280	325	156	129	M6	19	40	6	21.5	15.5	120	100	80	M6	3	10	+.009 -.004 (j6)	+.0 -.036 (h9)	
90S	310	365	176	134	M8	24	50	8	27	20	140	115	95	M8	3	10			
90L	338	393	176	134	M8	24	50	8	27	20	140	115	95	M8	3	10			
100L	375	440	192	148	M10	28	60	8	31	24	160	130	110	M8	3.5	11			
112M	392	457	217	158	M10	28	60	8	31	24	160	130	110	M8	3.5	11			

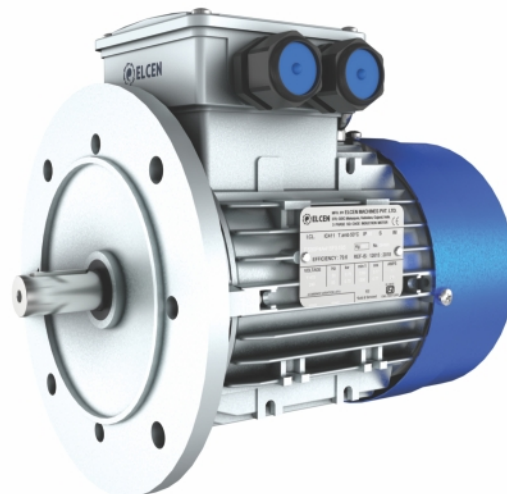
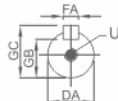
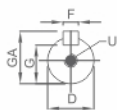

ALUMINIUM SERIES

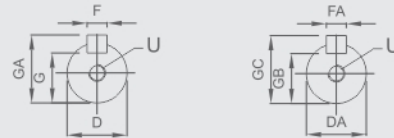
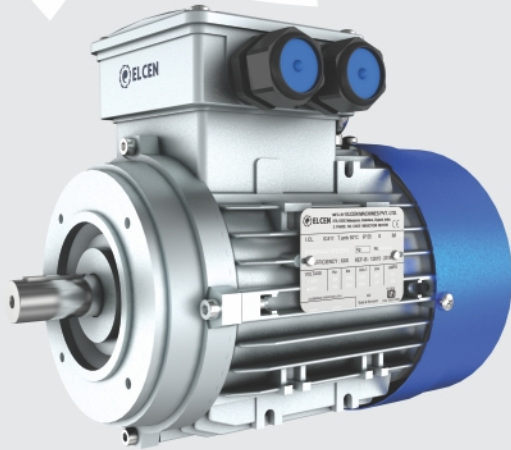

IE2 - MOTOR (FACE MOUNTED)

Mechanical Dimension (B14 Construction)

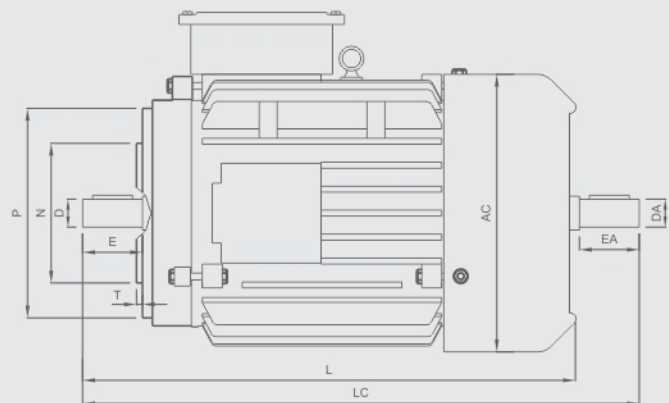
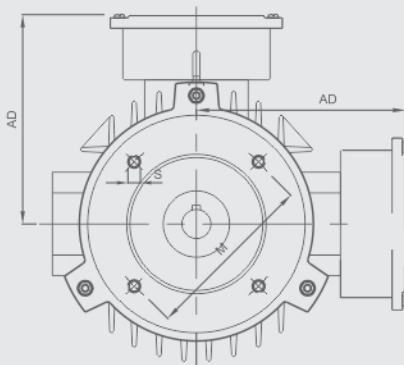

Frame Size	L	LC	AC	AD	U	D DA	E EA	F FA	GA GC	G GB	P MAX	M	N	S	T MAX	TOL ON D,DA	TOL ON F,FA	TOL ON H
63	212	242	122	95	M4	11	23	4	12.5	8.5	140	115	95	10	3	0.008 -0.003 (j6)	0 -0.03 (h9)	±0.3
71	238	275	137	111	M5	14	30	5	16	11	160	130	11	10	3.5			
80	280	225	156	128	M6	19	40	6	21.5	15.5	200	165	130	12	3.5			
90S	312	369	176	144	M8	24	50	8	27	20	200	165	130	12	3.5			
90L	338	393	176	135	M8	24	50	8	27	20	200	165	130	12	3.5			
100L	373	438	192	154	M10	28	60	8	31	24	250	215	180	15	4	0.009 -0.001 (j6)	0 -0.036 (h9)	±0.3
112M	393	458	217	158	M10	28	60	8	31	24	250	215	180	15	4			

ALUMINIUM SERIES

BRAKE MOTORS

DESCRIPTION

"ELCEN" Brake motors are normally supplied with fail safe brakes, also known as normally ON brake. The Motor is braked (Locked) when power is not applied i.e. de-energized to brake. This ensures real fail safe braking. The Construction is quite robust and requires very limited maintenance. With wearing of liners on the rotor of brake, the air – gap can be easily adjusted. If necessary. The rotor can be replaced completely as will, The brake is mounted on end cover on non-driving end of the motor. It comes with a Manual release lever. Depending upon the application requirement, AC or DC brake can be used.

Type of Load	Safety Factor
Low mass, uniform loading, non-intermittent operation	2
Low mass, light shock load with intermittent operation	2.5
Medium mass, light shock load with intermittent operation	3
Heavy mass, light shock load with intermittent operation	3
Overhauling Loads	3.5

Service factors for guidelines are mentioned in the selection table.

How ever while selecting the service factor, other criteria like mounting positions, type of transmission and reductions should also be considered as well.

SELECTION

Depending upon the application, the service factor of the brake has to be selected for proper braking.

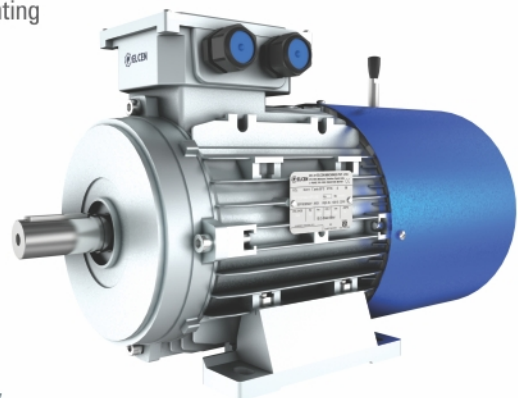

STD B3 AL BRK

Frame Size	A	B	C	H	K	L	LC	AA	AB	BB	BA	AC	HA	U	AD	D DA	E EA	F FA	GA GC	G GB	TOL ON D, DA	TOL ON F, FA	TOL ON H
63	100	80	40	63	7	265	294	31	125	105	25	120	10	M4	95	11	23	4	12.5	8.5	+.008 -.003 (j6)	+.0 -.030 (h9)	±0.5
71	112	90	45	71	7	310	345	35	140	108	35	138	10	M5	124	14	30	5	16	11			
80	125	100	50	80	10	342	387	40	160	125	40	158	13	M6	143	18	40	6	21.5	15.5	+.009 -.004 (j6)	+.0 -.036 (h9)	
90S	140	100	56	90	10	409	465	37	175	132	45	175	14	M8	145	24	50	8	27	20			
90L	140	125	56	90	10	409	465	37	175	157	45	175	14	M8	145	24	50	8	27	20			
100L	160	140	63	100	12	462	530	42	200	170	50	199	14	M10	155	28	60	8	31	24			
112M	190	140	70	112	12	478	545	50	225	175	57	217	14	M12	158	28	60	8	31	24			

ALUMINIUM SERIES

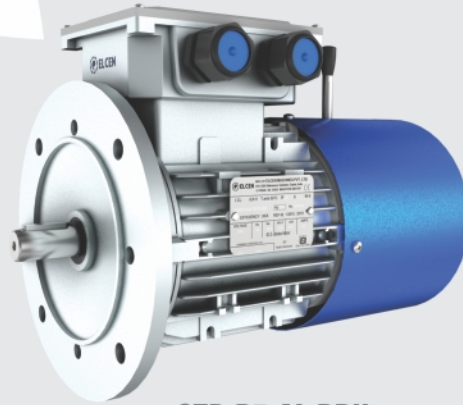

STD B5 AL BRK

Frame Size	L	LC	AC	AD	U	D DA	E EA	F FA	GA GC	G GB	P MAX	M	N	S	T MAX	LA	TOL ON D,DA	TOL ON F,FA	TOL ON H
63	265	294	120	95	M4	11	23	4	12.5	8.5	90	75	60	M5	2.5	9	+.0087 -.003 (j6)	+.000 -.030 (h9)	±0.3
71	308	375	138	111	M5	14	30	5	16	11	105	85	70	M6	2.5	9			
80	338	385	158	140	M6	19	40	6	21.5	15.5	120	100	80	M6	3	10	+.009 -.004 (j6)	+.0 -.036 (h9)	
90S	389	445	175	145	M8	24	50	8	27	20	140	115	95	M8	3	10			
90L	412	467	175	134	M8	24	50	8	27	20	140	115	95	M8	3	10			
100L	468	533	199	148	M10	28	60	8	31	24	160	130	110	M8	3.5	11			
112M	496	560	217	158	M10	28	60	8	31	24	160	130	110	M8	3.5	11			

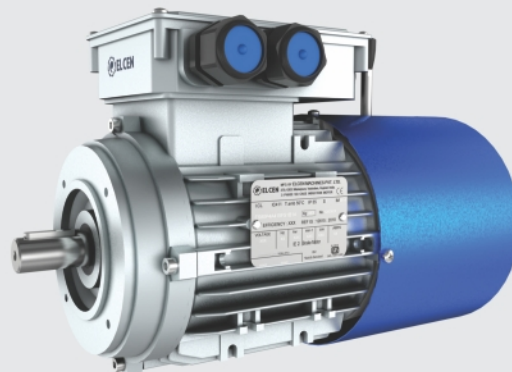

STD B14 AL BRK

Frame Size	L	LC	AC	AD	U	D DA	E EA	F FA	GA GC	G GB	P MAX	M	N	S	T MAX	TOL ON D,DA	TOL ON F,FA	TOL ON H
63	265	294	120	95	M4	11	23	4	12.5	8.5	140	115	95	10	3	0.008 -0.003 (j6)	0 -0.03 (h9)	±0.3
71	308	375	138	111	M5	14	30	5	16	11	160	130	11	10	3.5			
80	336	381	158	128	M6	19	40	6	21.5	15.5	200	165	130	12	3.5	0.009 -0.001 (j6)	0 -0.036 (h9)	
90S	421	476	175	145	M8	24	50	8	27	20	200	165	130	12	3.5			
90L	421	476	175	145	M8	24	50	8	27	20	200	165	130	12	3.5			
100L	473	538	199	154	M10	28	60	8	31	24	250	215	180	15	4			
112M	477	542	217	158	M10	28	60	8	31	24	250	215	180	15	4			

ALUMINIUM SERIES

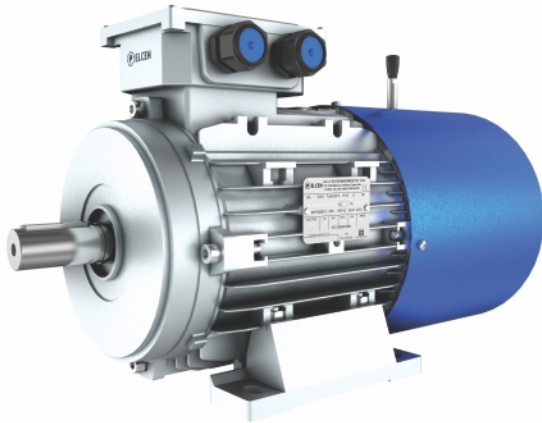

Unless otherwise specified, in AC fail safe brake, 415V 3 phase AC voltage brakes are supplied. Where as in DC fail safe brake. Brake voltages are 190V D.C., with a rectifier of 415V A.C. dual phase input and 190V D.C. output, duly fitted in the terminal box of the motor. For quicker releasing action of DC brake, 96V D.C. brakes can be used with the same rectifier but without rectifier. For these supply voltages of brake, inbuilt rectifier is not available, hence the brake, supply voltage of 230V or 110V AC, 3 phase can be supplied.

(DC) BRAKE MOTOR WIRING DETAILS

SWITCHING (D.C. brakes)

Motors are connected with AC switching as standard. For faster action and reduction of the delay in operation, DC switching can be used. Care must be taken with DC switching as it generates heavy sparking, which can lead to shorting of switching contacts and ultimately leads to failure of contact braking. Suitable universal shock suppressors and capacitors can be used (not in the scope of "ELCEN")

OPTIONS

Energized to brake (Normally off) brakes in different operating voltage can be supplied subject to confirmation. Rear side shaft extension for manual rotation of motor can be supplied if required.

LENGTH

As brake is mounted on the rear side of the motor, length of motor increases.

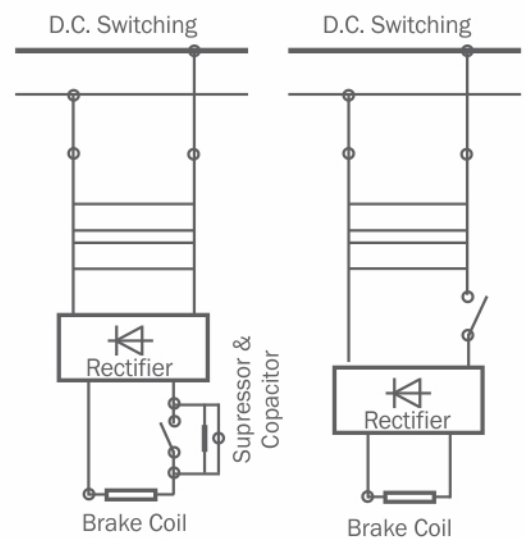

DUAL SPEED MOTORS

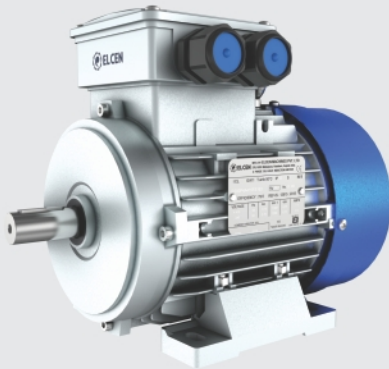

A Variety applications such as machine tools, fan and pumps, joists and cranes, positioning equipment and many others need dual speed motors. Dual speed motors. Dual speeds can be achieved either by separate winding or by changing the speed; the output power of the motor changes but the torque remains almost constant. The best motor for the application can be selected from the table below. For quantity requirements special ratings can be developed.

Pole →	2/4	4/6	4/8	6/8
Frame ↓	Horse Power			
71	-	-	0.18/0.09	-
90S	1.2/0.6	0.5/0.33	0.5/0.25	-
90L	2.0/1.4	-	-	-
90L	1.7/1.1	-	-	-
90L	2.0/0.4	-	-	-
90L	1.2/0.8	1.0/0.75	0.75/0.37	-
100L	3.2/1.6	1.5/1.1	1.5/0.75	-
112M	-	2.0/0.98	-	-
112M	5.0/2.5	3.0/2.13	2.6/1.3	-
132S	7.0/3.5	5.0/3.33	4.0/2.0	-
132M	-	-	-	-
132M	-	5.5/2.5	-	-
132M	-	7.0/3.5	5.5/2.2	-
132M	8.0/4.0	6.0/3.0	7.5/5.5	-
160M	15.0/10.0	10.0/7.5	10.0/5.0	7.5/5.0
160L	20.0/15.0	15.0/10.0	15.0/7.5	10.0/7.5
180M	25.0/15.0	17.5/12.5	17.5/8.4	12.5/8.4
180L	-	-	20.0/15.0	-

DUAL VOLTAGE MOTORS

Dual Voltage Motors can be Supplied with The voltage ration of either 1 : 1.73 or 2 : 1

Voltage Ratio	690	460	415	380	220
1 : 1.73	400	265	240	220	130
2 : 1	350	230	210	190	110

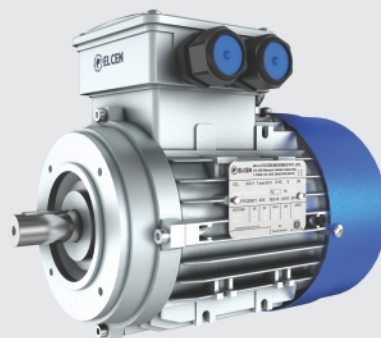

ALUMINIUM SERIES

CRANE MOTORS

"ELCEN" brand crane duty motors are specially designed for frequent starts / stops & reversing required in cranes & lifts of all types. They can also be used in applications such as material handling weirs & sluices auxiliary motors in rolling mills or wherever intermittent drives are required.

CONSTRUCTION

Castings: "ELCEN" crane duty motor's housings & endshields are made from high quality castings as per IS: 210. All components are machined to correct accuracy & alignment.

Terminal Box: Standard location of terminal box is on top. However the terminal box on right or left side can be provided on request. The terminal box can be rotated in steps of 90° in each position. Motors up to 250 frames have aluminum boxes whereas frames 280 & 315 are with cast iron terminal boxes.

Winding & Protection: All motors are wound with super enameled dual coast copper wires. This enable motors to be used for inverter applications as well. Features like vacuum pressure impregnation (VPI) & PTC thermistors embedded in stator winding can be provided on request.

Stampings: Stampings are made from low loss high permeability steel.

Earthing terminals : Two earthing terminals are provided one in the terminal box & other on the motor body.

Anti-condensation Heater: To avoid moisture accumulation inside the motor, the motor windings can be heated by connecting 4-10% of rated voltage to the motor terminals. This will generate enough heat equivalent to 20-25% of rated current. Alternatively any method as described in IS:900 can be used. Motor can also be offered with space heaters on request for frames 100 & above.

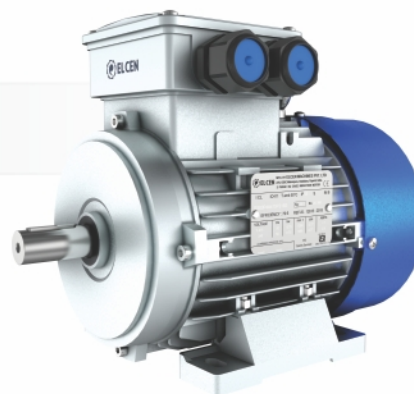

RANGE

KW	: 0.18 to 45 kW
RPM	: 1500, 1000, 750
Mounting	: Foot (B3), Flange (B5), Face (B14) & combinations
Frame	: 71 to 225M
Voltage	: 415V ± 10% or as required
Frequency	: 50Hz ± 5% or as required
Ambient	: 45C. (Refer Table 1)
Altitude	: Upto 1000m above msl (Refer Table 2)
Rotor type	: Squirrel cage aluminium die cast
Enclosure	: Totally enclosed fan cooled (TEFC)
Protection	: Ip55
Insl. Class	: Class F insulation with temp. rise limited to class B
Duty cycle	: S3, S4 & S5
Standards	: IS: 325, IS: 1231, IS: 2223 & IS:4722

MOTORS WITH INTEGRAL BRAKES

These motors can also be supplied with integral electromagnetic DC fail safe brakes with built in rectifiers for frames up to 200L.

ENQUIRY DETAILS

When placing an enquiry, please furnish the following details;

- Application details
- Motor power & speed
- Voltage & frequency variations
- Mounting
- No. of Start / Stops per hour with duty & CDF
- Load GD² at motor speed
- Load torque or torque / speed curve of driven equipment
- Duty cycle diagram if other than those described herein

Table 1

Ambient temp (°C)	Deration factor for Power
45°C	1.00
50°C	0.96
55°C	0.92
60°C	0.87

Table 2

Altitude above msl (m)	Deration factor for Power
1000	1.00
1500	0.97
2000	0.94
2500	0.90
3000	0.86

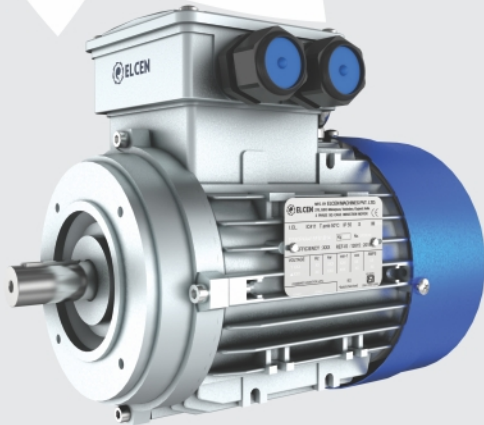

INVERTER RATED MOTORS

FREQUENCY INVERTER OR VFD DUTY

Machine tools and process equipment can perform better if the speed of the prime mover can be controlled. This requirement leads to use of Variable Frequency Inverters or Drives, popularly known as VFDs in combination with the electric motors. It is advisable to use Inverted Rated motors while controlling the motor through VFDs. Invert Rated Insulation protects the motor from voltage spikes and surges generated while operating the motor with VFDs. Depending upon the requirement, motor can be selected.

(A) Where speed of the motor is to be reduced approximately up to 50% of the rated speed. An integral (directly driven) fan mounted on the motor shaft provides sufficient cooling (IC41 Cooling). Hence only insulation system becomes important which provides protection against voltage spikes and surges.

(B) Where the speed of the motor to be reduced further the integral fan mounted on the motor shaft becomes inactive OR when the speed of the motor is to be increased with a frequency above 60 Hz, the integral fan overloads the motor.

In such a situation, it becomes very important to provide cooling by a separately powered fan servo ventilation (IC 46 cooling) Servo ventilation (IC 46 cooling) is available from frame size 71 to 225M.

When to motors are to be used in synchronization, positioning or similar applications, "ELCEN" motors available with rotary optional encoders. The criteria for selection of cooling system remains as described earlier. Depending upon the speed. Either integral cooling fan or servo ventilated cooling can be selected. As a standard 1024PPR incremental encoder, with 4.75V to 26.8V with short circuit push-pull output and RS422 functionality at 5V operation, how ever if application demands, either incremental or absolute can be supplied fitted with the motor.

Servo Ventilated motors, encoder fitted motors with or without servo ventilation are longer then the standard motor. Conform the length at the time of selection.

CAST IRON SERIES



MOCI SERIES IE2 HI-EFFICIENT MOTORS

In today's power scenario, we are facing a major power crunch. Day by day, the gap between demand & supply of electric energy is widening at the rate of 3%. Bridging this gap from supply side is very difficult & expensive proposition. The only viable way in handling these crises, in addition to capacity addition, is the efficient use of available energy, which is possible by use of energy efficient devices.

Electric motors are industry's basic need. Electric motors consume around 70% of the total electricity used in the industrial sector. As motors are the largest users of electrical energy, even small efficiency improvements can produce large savings across the country. Energy conservation measure taken by individual consumers in this direction can improve the national economy & benefit the environment on global scale. An energy efficient motor produces the same shaft output power but draws less input power than a standard motor. Hence energy efficient motor consumes less electricity than comparable standard motor.

FEATURES

- Standards : IS: 12615, IS: 1231, IS: 2223 & IEC-60034-1
- Mounting : Foot (B3), Flange (B5), Face (B14) & combi.
- Voltage : 415V \pm 10% or as required
- Frequency : 50Hz \pm 5% or as required
- Ambient : 50°C.
- Altitude : Upto 1000m above m.s.l.
- Enclosure : Totally enclosed fan cooled (TEFC)
- Protection : IP55
- Ins. Class : Class F Ins. With temp. rise limited to class B.

ADVANTAGES

- ▣ Saves energy & money
- ▣ Near uniform efficiency from 50% to 100% of full load ensuring energy savings even at part load conditions
- ▣ Short payback period
- ▣ Substantial savings after payback period

RANGE

"ELCEN" Energy efficient motor are designed as per the values specified in IS: 12615. They have near uniform efficiencies between 50 & 100% of load as shown in the figure. The motors are available from 2.2kW to 200.0kW in 2 & 4 pole variety as given in the performance tables. Performance figures of 6 & 8 pole motors are available upon request



EFFICIENCY LEVEL

"ELCEN" standard motors are with IE 2.

Pole	Kw	0.37	0.55	0.75	1.1	1.5	2.2	3.7	5.5	7.5	11	15	18.5	22	30	37	45
2	Efficiency in %	72.2	74.8	77.4	79.6	81.3	83.2	85.5	87	88.1	89.4	90.3	90.9	91.3	92	92.5	92.9
		70.1	75.1	79.6	81.4	82.8	84.3	86.3	87.7	88.7	89.8	90.6	91.2	91.6	92.3	92.7	93.1

CAST IRON SERIES



IE2 - MOTOR (FOOT MOUNTED)

Mechanical Dimension (B3 Construction)

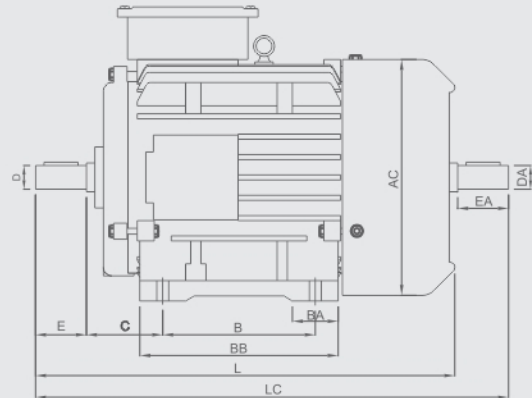
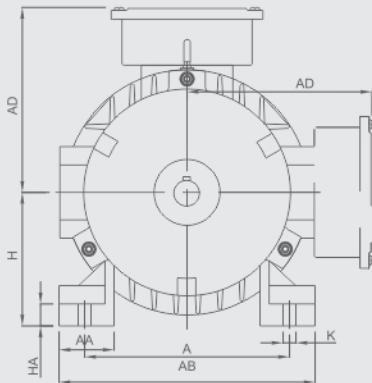

Frame Size	A	B	C	H	K	L	LC	AA	AB	BB	BA	AC	HA	U	AD	D DA	E EA	F FA	GA GC	G GB	TOL ON D, DA	TOL ON F, FA	TOL ON H
80	125	100	50	80	10	275	323	33.5	157	130	40	155	13	M6	129	19	40	6	21.5	15.5	+.009 -.004 (j6)	+.0 -.036 (h9)	±0.5
90S	140	100	56	90	10	305	363	40	180	162	45	177	14	M8	138	24	50	8	27	20			
90L	140	125	56	90	10	322	380	40	180	162	45	177	14	M8	138	24	50	8	27	20			
100L	160	140	63	100	12	374	442	45	200	174	50	199	14	M10	165	28	60	8	31	24			
112M	190	140	70	112	12	402	460	45	220	180	57	224	14	M12	178	28	60	8	31	245	h9	+.000 -.043 (h9)	
132S	216	140	89	132	12	447	535	46	256	200	60	266	18	M12	198	38	80	10	41	33			
132M	216	178	89	132	12	502	590	46	256	200	60	266	18	M16	198	38	80	10	41	33	+.018 +.002 (k6)	+.000 -.043 (h9)	
160M	254	210	108	160	15	591	709	72	326	286	78	322	25	M16	240	42	110	12	45	34			
160L	254	254	108	160	15	591	709	72	326	286	78	322	25	M20	240	42	110	12	45	34	+.018 +.002 (k6)	+.000 -.043 (h9)	
180M	279	241	121	180	15	695	815	80	360	338	95	354	25	M20	260	48	110	14	51.5	42.5			
180L	279	279	121	180	15	695	815	80	360	338	95	354	25	M20	260	48	110	14	51.5	42.5	+.018 +.002 (k6)	+.000 -.043 (h9)	
200L	318	305	133	200	19	754	872	96	389	368	95	404	30	M20	295	55	110	16	59	49			
225M	356	311	149	225	19	824	942	70	427	404	110	404	35	M20	320	55/60	110/140	16/18	59/64	49/53	+.018 +.002 (k6)	+.000 -.043 (h9)	

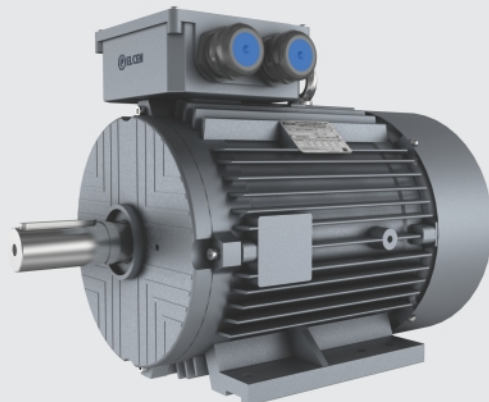
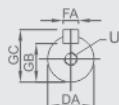
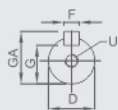

CAST IRON SERIES

IE2 - MOTOR (FLANGE MOUNTED)

Mechanical Dimension (B5 Construction)

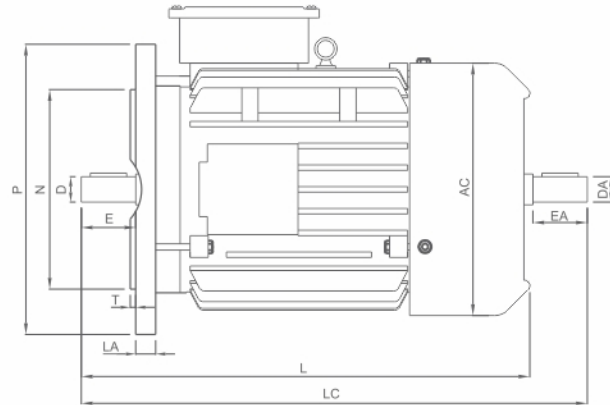
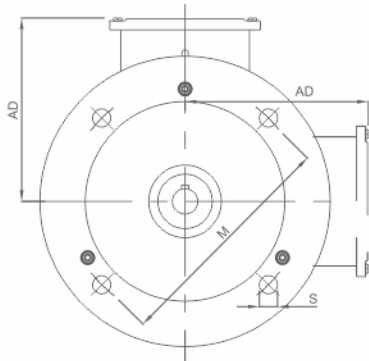

Frame Size	L	LC	AC	AD	U	D DA	E EA	F FA	GA GC	G GB	P MAX	M	N	S	T MAX	LA	TOL ON D, DA	TOL ON F, FA	TOL ON H
80	286	334	155	128	M6	19	40	6	21.5	15.5	200	165	130	12	3.5	10	+.009 -.004 (i6)	+.000 -.030 (h9)	±0.3
90S	316	374	177	135	M8	24	50	8	27	20	200	165	130	12	3.5	10			
90L	331	389	177	135	M8	24	50	8	27	20	200	165	130	12	3.5	10			
100L	365	433	199	165	M10	28	60	8	31	24	250	215	180	15	4	11	+.000 -.036 (h9)	±0.3	
112M	401	469	224	178	M10	28	60	8	31	24	250	215	180	15	4	11			
132S	456	544	266	198	M12	38	80	10	41	33	300	265	230	15	4	12			
132M	498	582	266	198	M12	38	80	10	41	33	300	265	230	15	4	12	+.018 -.002 (i6)	±0.3	
160M	605	723	322	240	M16	42	110	12	45	37	350	300	25	19	5	13			
160L	650	765	322	240	M16	42	110	12	45	37	350	300	25	19	5	13			
180M	686	804	354	260	M16	48	110	14	51.5	42.5	350	300	25	19	5	13	+.030 -.011 (m6)	±0.3	
180L	686	804	354	260	M16	48	110	14	51.5	42.5	350	300	25	19	5	13			
200L	754	872	404	295	M20	55	110	16	59	49	400	350	300	19	5	15	+.030 -.011 (m6)	±0.3	
225M	824	972	404	320	M20	55/60	110/140	16/18	59/64	49/53	450	400	350	19	5	16			

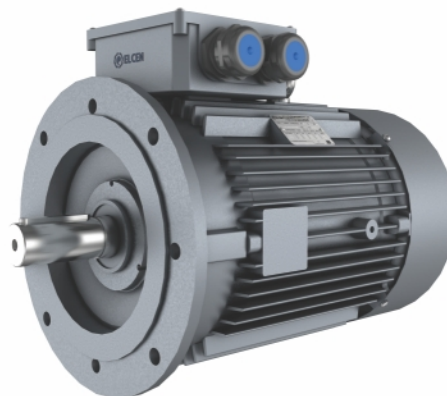
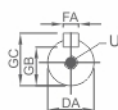
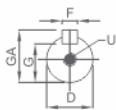

CAST IRON SERIES

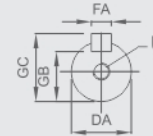
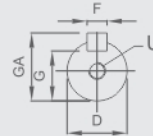

IE2 - MOTOR (FACE MOUNTED)

Mechanical Dimension (B14 Construction)

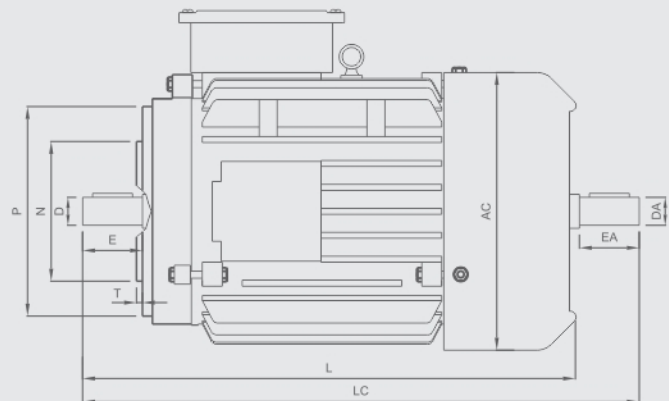
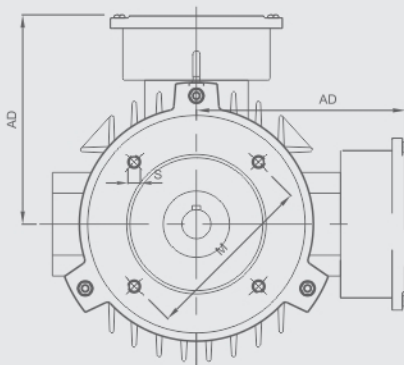

Frame Size	L	LC	AC	AD	U	D DA	E EA	F FA	GA GC	G GB	P MAX	M	N	S	T MAX	TOL ON D,DA	TOL ON F,FA	TOL ON M
80	265	313	155	128	M6	19	40	6	21.5	15.5	200	165	130	12	3.5	0.0087 -0.003 (j6)	0 -0.030 (h9)	
90S	320	378	177	144	M8	24	50	8	27	20	200	165	130	12	3.5			
90L	326	384	177	144	M8	24	50	8	27	20	200	165	130	12	3.5			
100L	375	443	199	165	M10	28	60	8	31	24	250	215	180	15	4			±0.3
112M	400	466	224	178	M10	28	60	8	31	24	250	215	180	15	4	0.009 -0.004 (j6)	0 -0.036 (h9)	
132S	450	538	266	198	M12	38	80	10	41	33	300	265	230	15	4			
132M	488	576	266	198	M12	38	80	10	41	33	300	265	230	15	4			

CAST IRON SERIES

BRAKE MOTORS

DESCRIPTION

"ELCEN" Brake motors are normally supplied with fail safe brakes, also known as normally ON brake. The Motor is braked (Locked) when power is not applied i.e. de-energized to brake. This ensures real fail safe braking. The Construction is quite robust and requires very limited maintenance. With wearing of liners on the rotor of brake, the air – gap can be easily adjusted. If necessary. The rotor can be replaced completely as will, The brake is mounted on end cover on non-driving end of the motor. It comes with a Manual release lever. Depending upon the application requirement, AC or DC brake can be used.

Type of Load	Safety Factor
Low mass, uniform loading, non-intermittent operation	2
Low mass, light shock load with intermittent operation	2.5
Medium mass, light shock load with intermittent operation	3
Heavy mass, light shock load with intermittent operation	3
Overhauling Loads	3.5

Service factors for guidelines are mentioned in the selection table.

How ever while selecting the service factor, other criteria like mounting positions, type of transmission and reductions should also be considered as well.

SELECTION

Depending upon the application, the service factor of the brake has to be selected for proper braking.

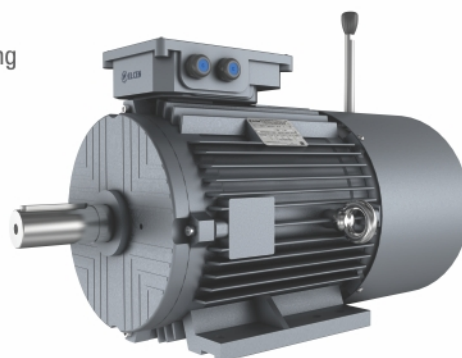

STD B3 CI BRK

Frame Size	A	B	C	H	K	L	LC	AA	AB	BB	BA	AC	HA	U	AD	D DA	E EA	F FA	GA GC	G GB	TOL ON D, DA	TOL ON F, FA	TOL ON H
80	125	100	50	80	10	344	392	33.5	157	130	40	155	13	M6	129	19	40	6	21.5	15.5	+.009 -.004 (j6)	+.000 -.036 (h9)	±0.5
90S	140	100	56	90	10	370	428	40	180	162	45	177	14	M8	138	24	50	8	27	20			
90L	140	125	56	90	10	398	456	40	180	162	45	177	14	M8	138	24	50	8	27	20			
100L	160	140	63	100	12	474	542	45	200	174	50	199	14	M10	165	28	60	8	31	24			
112M	190	140	70	112	12	480	549	45	220	180	57	224	14	M12	178	28	60	8	31	24.5			
132S	216	140	89	132	12	588	676	46	256	200	60	266	18	M12	198	38	80	10	41	33	+.018 +.002 (j6)	+.000 -.043 (h9)	
132M	216	178	89	132	12	604	692	46	256	200	60	266	18	M16	198	38	80	10	41	33			
160M	254	210	108	160	15	700	818	72	326	286	78	322	25	M16	240	42	110	12	45	34	+.000 -.043 (h9)		
160L	254	254	108	160	15	720	838	72	326	286	78	322	25	M20	240	42	110	12	45	34			
180M	279	241	121	180	15	814	932	80	360	338	95	354	25	M20	260	48	110	14	51.5	42.5			
180L	279	279	121	180	15	814	932	80	360	338	95	354	25	M20	260	48	110	14	51.5	42.5			

CAST IRON SERIES



ELCEN

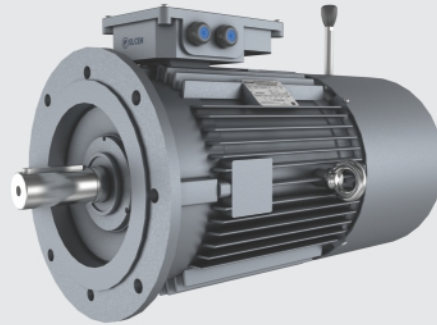

STD B5 CI BRK

Frame Size	L	LC	AC	AD	U	D DA	E EA	F FA	GA GC	G GB	P MAX	M	N	S	T MAX	LA	TOL ON D,DA	TOL ON F,FA	TOL ON H
80	337	377	155	128	M6	19	40	6	21.5	15.5	200	165	130	12	3.5	10	+.009 -.004 (j6)	+.000 -.030 (h9)	±0.3
90S	385	443	177	135	M8	24	50	8	27	20	200	165	130	12	3.5	10			
90L	410	468	177	135	M8	24	50	8	27	20	200	165	130	12	3.5	10			
100L	474	542	199	165	M10	28	60	8	31	24	250	215	180	15	4	11			
112M	480	549	224	178	M10	28	60	8	31	24	250	215	180	15	4	11			
132S	581	669	266	198	M12	38	80	10	41	33	300	265	230	15	4	12			
132M	623	711	266	198	M12	38	80	10	41	33	300	265	230	15	4	12	+.018 -.002 (j6)	+.000 -.043 (h9)	±0.5
160M	750	868	322	240	M16	42	110	12	45	37	350	300	250	19	5	13			
160L	750	868	322	240	M16	42	110	12	45	37	350	300	250	19	5	13			
180M	830	948	354	260	M16	48	110	14	51.5	42.5	350	300	250	19	5	13			
180L	830	948	354	260	M16	48	110	14	51.5	42.5	350	300	250	19	5	13			

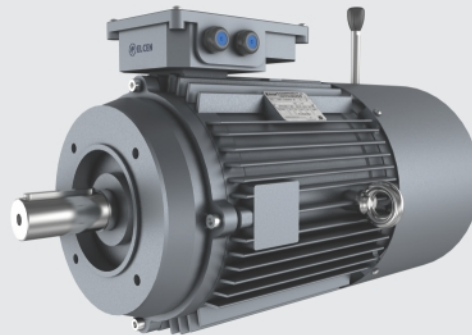

STD B14 CI BRK

Frame Size	L	LC	AC	AD	U	D DA	E EA	F FA	GA GC	G GB	P MAX	M	N	S	T MAX	TOL ON D,DA	TOL ON F,FA	TOL ON M
80	337	377	155	128	M6	19	40	6	21.5	15.5	200	165	130	12	3.5	0.0087 -0.003 (j6)	0 -0.030 (h9)	±0.3
90S	385	443	177	144	M8	24	50	8	27	20	200	165	130	12	3.5			
90L	410	468	177	144	M8	24	50	8	27	20	200	165	130	12	3.5			
100L	474	542	199	165	M10	28	60	8	31	24	250	215	180	15	4	0.009 -0.004 (j6)	0 -0.036 (h9)	
112M	480	549	224	178	M10	28	60	8	31	24	250	215	180	15	4			
132S	581	669	266	198	M12	38	80	10	41	33	300	265	230	15	4			
132M	623	711	266	198	M12	38	80	10	41	33	300	265	230	15	4			

CAST IRON SERIES



Unless otherwise specified, in AC fail safe brake, 415V 3 phase AC voltage brakes are supplied. Where as in DC fail safe brake. Brake voltages are 190V D.C., with a rectifier of 415V A.C. dual phase input and 190V D.C. output, duly fitted in the terminal box of the motor. For quicker releasing action of DC brake, 96V D.C. brakes can be used with the same rectifier but without rectifier. For these supply voltages of brake, inbuilt rectifier is not available, hence the brake, supply voltage of 230V or 110V AC, 3 phase can be supplied.

(DC) BRAKE MOTOR WIRING DETAILS

SWITCHING (D.C. brakes)

Motors are connected with AC switching as standard. For faster action and reduction of the delay in operation, DC switching can be used. Care must be taken with DC switching as it generates heavy sparking, which can lead to shorting of switching contacts and ultimately leads to failure of contact braking. Suitable universal shock suppressors and capacitors can be used (not in the scope of "ELCEN")

OPTIONS

Energized to brake (Normally off) brakes in different operating voltage can be supplied subject to confirmation. Rear side shaft extension for manual rotation of motor can be supplied if required.

LENGTH

As brake is mounted on the rear side of the motor, length of motor increases.

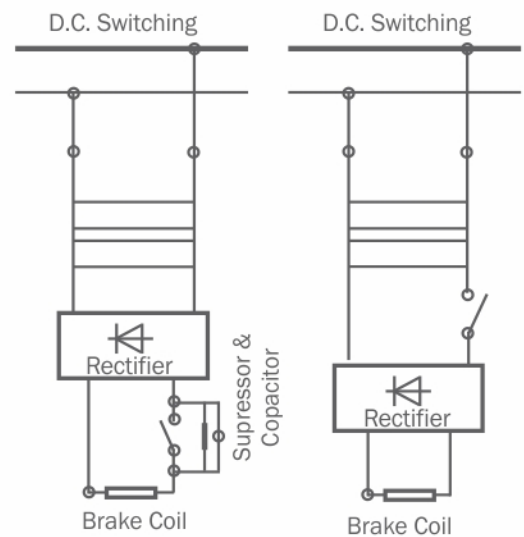

DUAL SPEED MOTORS

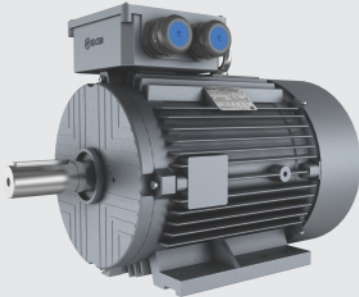

A Variety applications such as machine tools, fan and pumps, joists and cranes, positioning equipment and many others need dual speed motors. Dual speed motors. Dual speeds can be achieved either by separate winding or by changing the speed; the output power of the motor changes but the torque remains almost constant. The best motor for the application can be selected from the table below. For quantity requirements special ratings can be developed.

Pole →	2/4	4/6	4/8	6/8
Frame ↓	Horse Power			
71	-	-	0.18/0.09	-
90S	1.2/0.6	0.5/0.33	0.5/0.25	-
90L	2.0/1.4	-	-	-
90L	1.7/1.1	-	-	-
90L	2.0/0.4	-	-	-
90L	1.2/0.8	1.0/0.75	0.75/0.37	-
100L	3.2/1.6	1.5/1.1	1.5/0.75	-
112M	-	2.0/0.98	-	-
112M	5.0/2.5	3.0/2.13	2.6/1.3	-
132S	7.0/3.5	5.0/3.33	4.0/2.0	-
132M	-	-	-	-
132M	-	5.5/2.5	-	-
132M	-	7.0/3.5	5.5/2.2	-
132M	8.0/4.0	6.0/3.0	7.5/5.5	-
160M	15.0/10.0	10.0/7.5	10.0/5.0	7.5/5.0
160L	20.0/15.0	15.0/10.0	15.0/7.5	10.0/7.5
180M	25.0/15.0	17.5/12.5	17.5/8.4	12.5/8.4
180L	-	-	20.0/15.0	-

DUAL VOLTAGE MOTORS

Dual Voltage Motors can be Supplied with The voltage ration of either 1 : 1.73 or 2 : 1

Voltage Ratio	690	460	415	380	220
1 : 1.73	400	265	240	220	130
2 : 1	350	230	210	190	110



CAST IRON SERIES

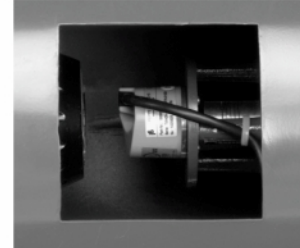
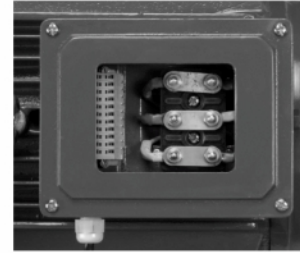

INVERTER RATED MOTORS

FREQUENCY INVERTER OR VFD DUTY

Machine tools and process equipment can perform better if the speed of the prime mover can be controlled. This requirement leads to use of Variable Frequency Inverters or Drives, popularly known as VFDs in combination with the electric motors. It is advisable to use Inverted Rated motors while controlling the motor through VFDs. Invert Rated Insulation protects the motor from voltage spikes and surges generated while operating the motor with VFDs. Depending upon the requirement, motor can be selected.

(A) Where speed of the motor is to be reduced approximately up to 50% of the rated speed. An integral (directly driven) fan mounted on the motor shaft provides sufficient cooling (IC41 Cooling). Hence only insulation system becomes important which provides protection against voltage spikes and surges.

(B) Where the speed of the motor to be reduced further the integral fan mounted on the motor shaft becomes inactive OR when the speed of the motor is to be increased with a frequency above 60 Hz, the

integral fan overloads the motor. In such a situation, it becomes very important to provide cooling by a separately powered fan servo ventilation (IC 46 cooling) Servo ventilation (IC 46 cooling) is available from frame size 71 to 225M.

(C) When to motors are to be used in synchronization, positioning or similar applications, "ELCEN" motors available with rotary optional encoders. The criteria for selection of cooling system remains as described earlier. Depending upon the speed. Either integral cooling fan or servo ventilated cooling can be selected. As a standard 1024PPR incremental encoder, with 4.75V to 26.8V with short circuit push-pull output and RS422 functionality at 5V operation, how ever if application demands, either incremental or absolute can be supplied fitted with the motor.

Servo Ventilated motors, encoder fitted motors with or without servo ventilation are longer then the standard motor. Conform the length at the time of selection.

TORQUE MOTORS

Torque motors are special induction motors with specific stall torque – speed characteristic curve. Torque Motors have high Slip Characteristic which can be smartly used in winder application, may it be plastic film or metallic wire. “ELCEN” make Torque Motor is a precision designed, of robust construction and is noted for its reliability in worst operating conditions. These motors are available in IEC frame size as well as modified Mechanical frames for special applications. Special frames as per customer requirement are also available.

A standard squirrel cage motor tries to maintain the speed as it is loaded while a Torque motor will drop in speed as it is loaded. The desired speed can also be achieved by varying supply voltage.

TORQUE IN KGM	HP	RPM	FRAME
0.072	0.075	750	71
0.048	0.1	750	63
0.096	0.1	150	80
0.096	0.2	1500	71
0.19	0.2	750	90S
0.12	0.25	1500	80
0.24	0.25	750	90L
0.24	0.5	150	90S
0.48	0.5	750	100L
0.31	0.65	1500	90L
0.72	0.75	750	112M
0.48	1.0	1500	100L
0.96	1.0	750	132S
1.44	1.5	750	132M
0.96	2.0	1500	112M
0.96	2.0	1500	132S
1.2	2.5	1500	132S
1.44	3.0	1500	132M
2.4	5.0	1500	160L

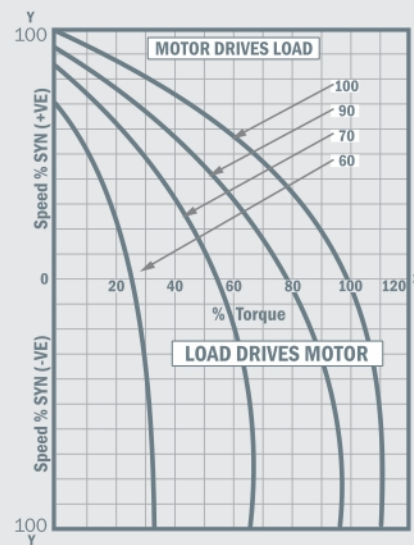

APPLICATION OF TORQUE MOTORS

HDPE Tapes, Monofilament- yarns, Box Strapping
 All types of extruded plastic films Rubberised Fabrics, textiles 20 to 100Hz, 50 to 250 V, flange mounting type. Copper Wires from 8 SWG. S.S. Wires from 8 SWG to 43 SWG. S.S. Wires/ M.S. Wires Strips of Copper, Mild Steel etc.

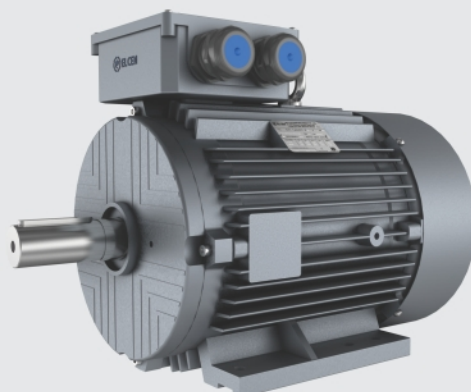

CAST IRON SERIES

CRANE MOTORS

"ELCEN" brand crane duty motors are specially designed for frequent starts / stops & reversing required in cranes & lifts of all types. They can also be used in applications such as material handling weirs & sluices auxiliary motors in rolling mills or wherever intermittent drives are required.

CONSTRUCTION

Castings: "ELCEN" crane duty motor's housings & endshields are made from high quality castings as per IS: 210. All components are machined to correct accuracy & alignment.

Terminal Box: Standard location of terminal box is on box is on top. However the terminal box on right or left side can be provided on request. The terminal box can be rotated in steps of 90° in each position. Motors up to 250 frames have aluminum boxes whereas frames 280 & 315 are with cast iron terminal boxes.

Winding & Protection: All motors are wound with super enameled dual coast copper wires. This enable motors to be used for inverter applications as well. Features like vacuum pressure impregnation (VPI) & PTC thermistors embedded in stator winding can be provided on request.

Stampings: Stampings are made from low loss high permeability steel.

Earthing terminals : Two earthing terminals are provided one in the terminal box & other on the motor body.

Anti-condensation Heater: To avoid moisture accumulation accumulation inside the motor, the motor windings can be heated by connecting 4-10% of rated voltage to the motor terminals. This will generate enough heat equivalent to 20-25% of rated current. Alternatively any method as described in IS:900 can be used. Motor can also be offered with space heaters on request for frames 100 & above.



RANGE

KW	: 0.18 to 45 kW
RPM	: 1500, 1000, 750
Mounting	: Foot (B3), Flange (B5), Face (B14) & combinations
Frame	: 71 to 225M
Voltage	: 415V ± 10% or as required
Frequency	: 50Hz ± 5% or as required
Ambient	: 45C. (Refer Table 1)
Altitude	: Upto 1000m above msl (Refer Table 2)
Rotor type	: Squirrel cage aluminium die cast
Enclosure	: Totally enclosed fan cooled (TEFC)
Protection	: Ip55
Insl. Class	: Class F insulation with temp. rise limited to class B
Duty cycle	: S3, S4 & S5
Standards	: IS: 325, IS: 1231, IS: 2223 & IS:4722

MOTORS WITH INTEGRAL BRAKES

These motors can also be supplied with integral electromagnetic DC fail safe brakes with built in rectifiers for frames up to 200L.

ENQUIRY DETAILS

When placing an enquiry, please furnish the following details;

- Application details
- Motor power & speed
- Voltage & frequency variations
- Mounting
- No. of Start / Stops per hour with duty & CDF
- Load GD² at motor speed
- Load torque or torque / speed curve of driven equipment
- Duty cycle diagram if other than those described herein

Table 1

Ambient temp (°C)	Deration factor for Power
45°C	1.00
50°C	0.96
55°C	0.92
60°C	0.87

Table 2

Altitude above msl (m)	Deration factor for Power
1000	1.00
1500	0.97
2000	0.94
2500	0.90
3000	0.86

CUSTOM BUILT MOTORS

Use of custom built motors many times results in make the application much easier, cost competitive of maintenance free. "ELCEN" has excelled in developing and manufacturing custom built motors. Motors with non standard flanges, Shaft dimensions or mounting bases can be manufacturing custom built motors. Motors with non standard flanges, shaft dimensions or mounting bases can be manufactured in economically attractive quantities. Different duty cycles at different speeds in dual speed motors OR different torque speed characteristic motors can be manufactured economically as well.

For special positioning purposes "ELCEN" has developed a dual speed brake motor with continuous duty at higher speed (power) and short time duty at lower speed (power) in 71 frame. Typically the motor starts at 0.18 kW/400 RPM continuous duty (S1). When it reaches near to the required position the motor rating will change to 0.09kW/670 RPM for a short time (S2 duty) of a second or two. Once it reaches the final position, it stops immediately with brake. With this mechanism, the positioning accuracy can be increased by 60% better.

For Stirrer applications ELCEN developed an extended shaft motor which eliminates the coupling, bearing housing and reduces a lot of mounting structure, which in turn reduces the overall cost and manufacturing time. AS the unit has less components, maintenance is also reduced.

Compact machines like humidifiers of similar where motor it self can become the frame for the mounting of other parts and components of the machine and can make the machine versatile and easy to operate.

"ELCEN" manufactures Vibrator Motors to suit the requirements of specific machines. The custom built vibrator motor are designed to suits the mounting and dismantling of the motor. "ELCEN" Vibrator Motors are widely applicable because of adjustable amplitude of vibration.

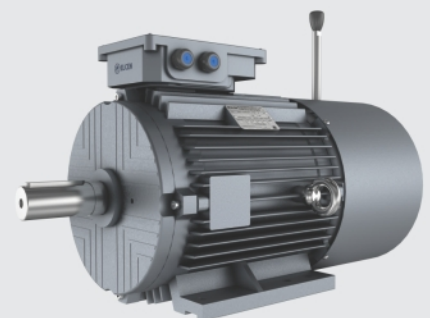
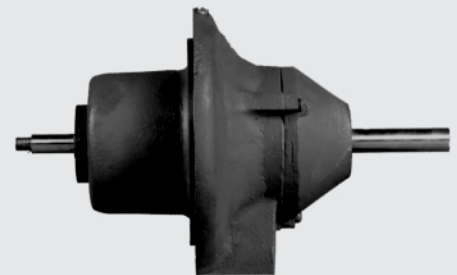
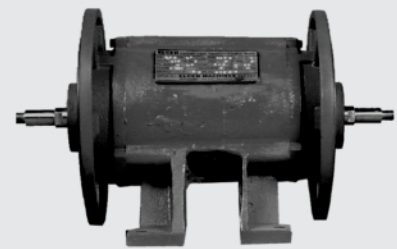

MOTOR DESIGNATION FOR INQUIRY AND ORDER

ES 71 P4 A 415 F S1 B5 V1 IP55 +.. +..

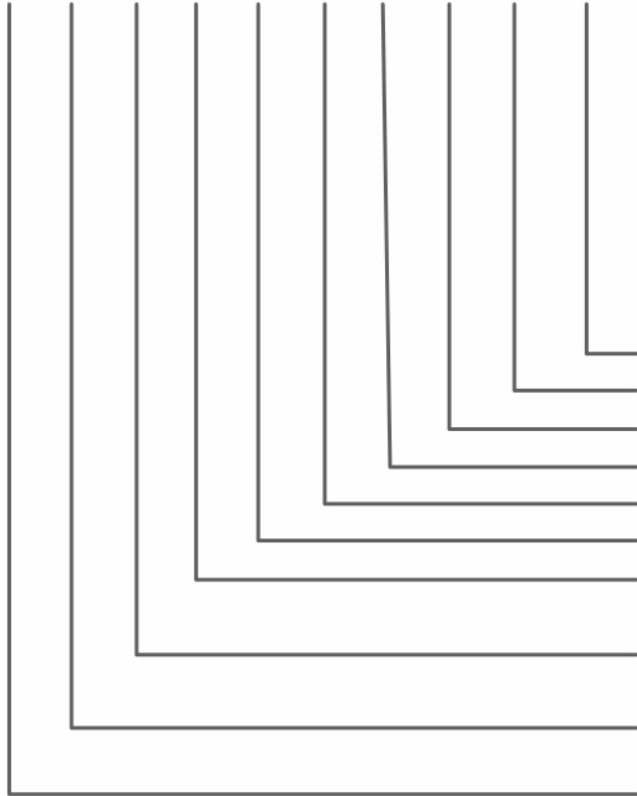

Optionals

- TH = Thermister
- TS = Integral Thermal Switch
- SH = Space Heater
- RN = Rain Guard
- OI = Incremental Optical Encoder (PPR like 1024)
- OA = Absolute Optical Encoder (PPR like 1024)
- SV = Servo Ventilation

Ip55 is standard Option IP 56

Installation Position

Mountings

Duty Cycle S1...S6

Class of Insulation F or H

Supply Voltage 415 / 380 / 220

Operating Frequency A=50 Hz, B=60Hz,

C = Special mention separately in options.

Pole of motor, mention dual poles

for dual speed motors i.e. 2/4 or 4/6

Frame Size

Type of Motors

- ES = Standard 3 Phase Motors (IE 1)
- EES = Energy Efficient Motors (IE 2)
- ED = Dual Speed Motors
- EB = Brake Motors
- ECD = Crane Duty Motors
- EI = Inverter Duty Motors
- EA = Custom Built Motors
- ET = Torque Motors
- EC = Cooling Tower Motors

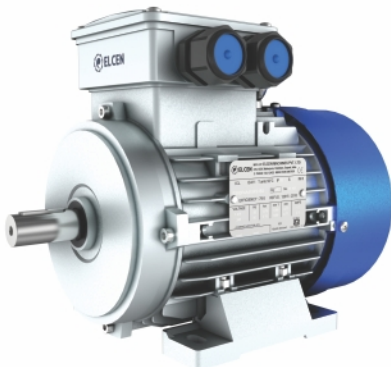



OUR SERVICE STATION

ANKLESHWAR	INDORE
AHMEDABAD	JAIPUR
AURANGABAD	JALGAON
BHOPAL	JAMSEDHPUR
BHUVNESHWAR	KOTA
BHILAI	KANPUR
BANGALORE	KOLKATA
BELGAUM	LUDHIANA
CHENNAI	MUMBAI
COIMBATORE	MEHSANA
CALICUT	NAGPUR
COCHIN	NASHIK
DAMAN	PUNE
DELHI	RAJKOT
GURGAON	SECUNDERABAD
GOA	THANE
GUWAHATI	TINSUKIA
GORAKHPUR	VUSHAKHAPATNAM
HYDERABAD	VADODARA

LOCATION

We are located at Vadodara,
State of Gujarat, India.

Vadodara is about

100 kms from "Ahmedabad"

450 kms from "Mumbai"

1030 kms from "New Delhi"

By Air : It takes about 1 hour from "Mumbai"

1 hour 15 minutes from "New Delhi"

By Road : It takes about 6 to 8 hours from "Mumbai"

2 hours from "Ahmedabad"

By Train : To and for over night train are available
from "Mumbai" and "New Delhi"

CONTACT

Information : info@elcen.com

Marketing : marketing@elcen.com

Services : services@elcen.com

Accounts : accounts@elcen.com

Purchase : purchase@elcen.com

NOTES

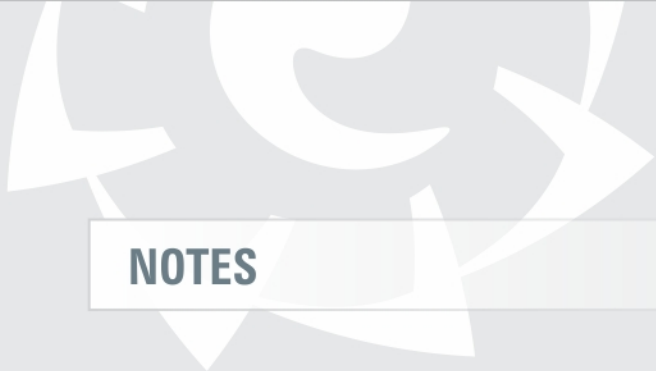

NOTES



ELCEN

50 YEARS
ANNIVERSARY



GST No.: 24AAACE4118Q1ZK
CIN No.: U29120GJ1973PTC002272



ELCEN MACHINES PVT. LTD.

270, G.I.D.C. Makarpura,
Vadodara - 390 010, Gujarat, INDIA

+ 91 265 2642001 | 90999 64240

info@elcen.com

www.elcen.com

